

Owner's Operating Manual

SP SERIES CONTINUOUS POWER SYSTEM

MODELS COVERED:

SP560

SP1250LE

CLARY CORPORATION

150 E. Huntington Dr.

Monrovia, California 91016

Telephone ☎ 626-359-4486

☎ 800-44 CLARY

Fax. ☎ 626-305-0254

Web 🌐 HTTP: // www.clary.com

Information contained herein is the property of Clary Corporation, is proprietary, confidential, and not to be disclosed, disseminated or used except for the purpose provided by

CLARY CORPORATION

TABLE OF CONTENTS

TITLE	PAGE
TABLE OF CONTENTS	2
INTRODUCTION	3
TECHNICAL DESCRIPTION	4
PACKAGING	5
PHYSICAL DESCRIPTION SP560	6
PHYSICAL DESCRIPTION SP1250LE	7
INSTALLATION	9
OPERATION	10
SIGNALS AND INTERFACING	11
USB SETUP	12
SPECIFICATIONS	15
BATTERY PACK (SP-48SB)	16
BYPASS BOX (SPH-302)	17
CARE AND MAINTENANCE	19
SERVICE AND REPAIR	22
WARRANTY	23

INTRODUCTION

Congratulations! You have selected the highest quality protection for your *continuous power* needs. This unit offers a quiet and compact package with superior performance you can depend on. You now own a **SP Series Continuous Power System (CPS)** which is an all *Digital Technology* product manufactured by **Clary Corporation**, the first name in uninterruptible power system (UPS) reliability. The *Continuous Power System* is the highest order in the hierarchy of UPS products. When power problems occur, there can be no compromising the reliability of your power solution. The **SP Series Continuous Power System** is your complete power solution.

This Owner's Operating Manual is provided with your new **SP Series UPS**. It will enhance your understanding of the product and its functions. **WE STRONGLY URGE YOU TO READ THIS MANUAL COMPLETELY, PRIOR TO BEGINNING INSTALLATION OR ATTEMPTING OPERATION.** This will save you time and effort in your installation and application, and it will assure a trouble free installation and startup session, thus enhancing public safety and the image of your agency. The illustrations provided will familiarize you with this product's operating modes and components. Always operate the unit within the guidelines and specifications provided to maximize safety and the lifetime of the unit. Also, your understanding of the product is a key element in getting the most out of your **SP Series UPS**.

IMPORTANT SAFETY INSTRUCTIONS, SAVE THESE INSTRUCTIONS

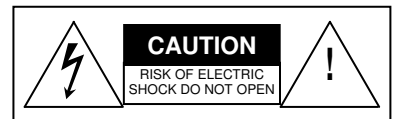
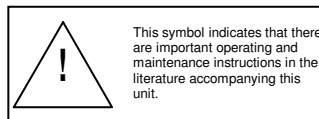
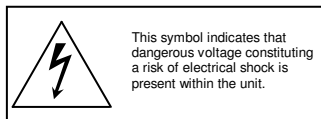

This manual contains important safety instructions that should be followed during installation and maintenance of the UPS and batteries. Be aware of the following symbols and their meaning as they appear throughout the manual:

TECHNICAL DESCRIPTION

The Digital Technology-Extreme Temperature SP560/SP1250LE Series *Continuous Power System (CPS)* is a revolutionary new concept in total power protection and management. The SP560/SP1250LE Series is a DSP processor-based UPS that allows the user to set most of the control feature parameters. By directly linking a personal computer to the SP560/SP1250LE Series Com ports, frequency settings and operation, alarm signals, load switching, fan operation, etc. can all be programmed to meet specific application requirements.

The SP560/SP1250LE Series is a true on-line, continuous power UPS. In the tradition of Clary products, the SP560/SP1250LE Series generates the same high quality and proven reliability to provide the best power protection available for today's critical applications.

In keeping with the state-of-the-art design, the power electronics are completely governed by an on-board DSP based processor. Given the powerful processing capability of today's DSP chips, this allows the UPS to evolve into an all-in-one complete power distribution and monitoring center. Not only is your critical load insured of the most reliable and constant power available, but the user may now continuously monitor the status of the various operational parameters in the system.

The AC utility source is connected to the power switching and control electronics when the input switch is closed. The input line is filtered, rectified and power factor corrected for enhanced performance without disturbing other equipment that may share the same utility circuit.

The DSP processor controls an *Inverter Generator* that produces a clean, low harmonic, AC output sinewave for continuous power applications.

When the input AC utility line fails, the battery circuit within this system takes over to ensure continuous power. Only when properly rated input power is returned, does the unit reconnect the input source back to the system.

The unit is connected to a Com port which allows the user to monitor and set operating parameters. With a simple link to a personal computer using the "SP560/SP1250LE UPS software program", the user can view the event history of the power distribution system. More sophisticated users may choose to implement the optional SNMP package to allow full *Network Power Management capability*.

PACKAGING

Your UPS has been carefully packaged to withstand most abuse sustained during shipment. The packing material has been specifically designed to protect this system for normal handling, using most shipping carriers. If there is significant damage to the carton, or if there is any physical damage to this unit, report this to your carrier.

These units are encapsulated in a protective wrap that comes apart once the product is removed from the shipping carton. Save all packing material for future use.

The packaging also contains important information on use and care as well as valuable warranty information. Read all materials before storing this literature with your other valuable product documents.

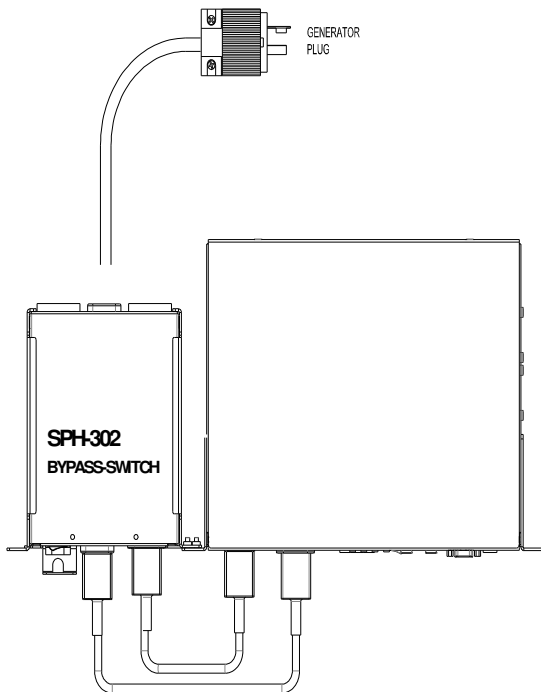
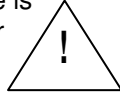

PHYSICAL DESCRIPTION SP560

This section will point out and illustrate the various indicators, functions and controls of the **SP560 and SP1250LE Series UPS**. The important attributes of the **SP560/SP1250LE Series** unit are numbered to assist you in locating them on your machine and also to fully explain its function and how it relates to system operation.

Numbers on the drawing will correspond to the operating component's name at the bottom with a brief identification. In the next section, a complete explanation of all numbered items will be enhanced to ensure you have a full understanding of the

visual indicators used on the front panel are long lasting, very efficient, light emitting diodes (LED). When operating the push-button switches, always hold the switch in for at least two seconds to insure function confirmation. This feature has been implemented into the system design to avoid inadvertent operation of any of the user-available functions.

Pictured below is the front view of the model SP560.

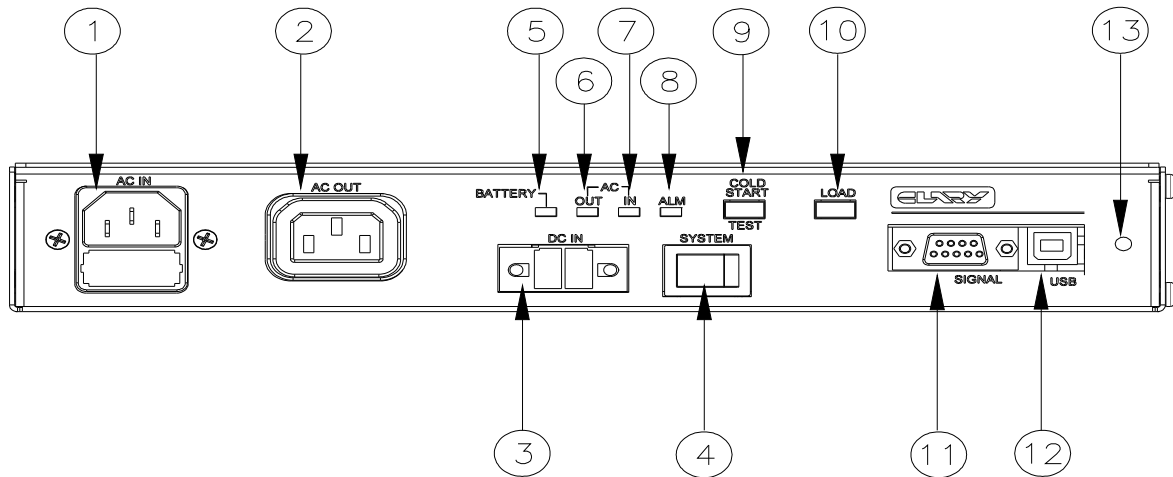

SP560 FRONT PANEL VIEW

- | | | | |
|---|---------------|----|------------------------|
| 1 | AC IN | 7 | AC IN LED |
| 2 | AC OUT | 8 | ALARM LED |
| 3 | DC IN | 9 | COLD START/TEST SWITCH |
| 4 | SYSTEM SWITCH | 10 | LOAD SWITCH |
| 5 | BATTERY LED | 11 | SIGNAL DB9 |
| 6 | AC OUT LED | 12 | USB TYPE B |
| | | 13 | PROGRAM SWITCH |

PHYSICAL DESCRIPTION SP1250LE

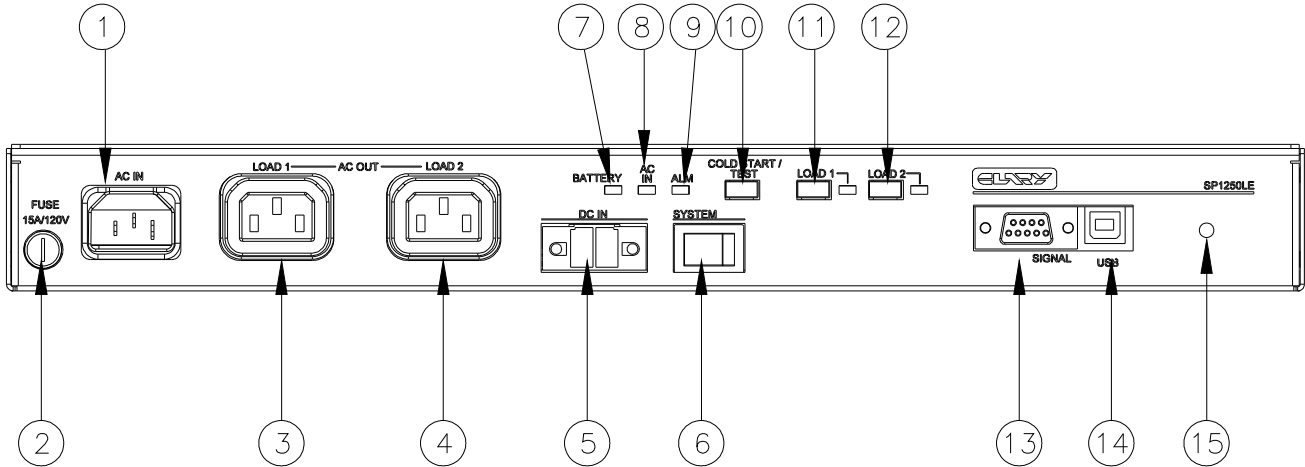

SP1250LE FRONT PANEL VIEW

- | | | | |
|---|-----------------|----|------------------------|
| 1 | AC IN | 8 | AC IN LED |
| 2 | AC IN FUSE | 9 | ALARM LED |
| 3 | AC OUT – LOAD 1 | 10 | COLD START/TEST SWITCH |
| 4 | AC OUT – LOAD 2 | 11 | LOAD 1 SWITCH |
| 5 | DC INPUT | 12 | LOAD 2 SWITCH |
| 6 | SYSTEM SWITCH | 13 | SIGNAL DB9 |
| 7 | BATTERY LED | 14 | USB TYPE B |
| | | 15 | PROGRAM SWITCH |

SUMMARY OF INDICATORS AND CONTROLS

AC IN – IEC Inlet C14 type used to supply utility power to the system.

INPUT FUSE – Input Inlet protection. SP560 - 10A, 250VAC, 5x20mm (slo-blo) fuse, SP1250LE – 15A, 250VAC, 3AG.

AC OUT – IEC Outlet C13 type used to supply 120VAC Inverter generated power provided. The SP1250LE provides two outlets labeled Load 1 and Load 2. They can be separately controlled via the Load 1 and Load 2 switches.

DC INPUT – A two position keyed connector provided for external 48V Batteries.

SYSTEM SWITCH – This switch is used to power up or down the unit. The switch must be in the ON position to AC or Cold start the unit.

BATTERY LED – Tri colored LED indicating battery condition. Green – Batteries are good, Yellow – Batteries are low (below 25% capacity), Red flashing– Batteries are depleted (below 10% capacity), LED Off – No batteries are connected.

AC OUT LED – Dual colored LED indicating AC output condition. Green solid – Inverter Output, Green flashing – Unit in Bypass, Red solid – Output bad, LED off – Output off.

AC IN LED – Dual colored LED indicating AC input condition. Green – AC input in range, Red – AC input not present or out of range.

ALARM LED – Red LED flashing indicating alarm active (On battery, OverTemp, Fan fail). Red LED solid indicates a more serious alarm (Low battery warning, Inverter/Component failure). To silence an audible alarm, quickly press and release any one of the push button switches (Cold Start/Test or Load).

COLD START/TEST SWITCH - This is a multi function push button switch. If no AC utility voltage is available, it may still be a requirement to initialize some equipment. See the operations section for information on cold start. Once Unit is running on AC Input, this switch becomes a Battery Test switch. See the operations section for information on Battery Test. This switch is also used to silence an audible alarm.

LOAD SWITCH – This is a multi function push button switch. Once this switch is pressed in for at least two seconds, output power will then be disabled to the AC Output. Pressing in this switch again for at least two seconds, output power will then be enabled to the AC Output. This switch is also used to silence an audible alarm.

SIGNAL DB 9 - A DB-9 subminiature, female connector provided for intelligent computer monitoring systems. See SIGNALS AND INTERFACING Section for specific pin-outs.

USB - Connector provided for intelligent computer monitoring systems. There is one USB Type A and one USB Type B connector provided on older units. Type A is not used, Type B is used to connect to your computer. Newer units will only have a Type B connector. See SIGNALS AND INTERFACING Section for specific pin-outs.

PROGRAM SWITCH – Used for updating firmware.

INSTALLATION

The system is lightweight and can be easily moved. Some important points to consider when positioning a unit for operation:

- The installation site should maintain an ambient air temperature of less than 165°F (74°C). When the environment for the system remains cooler during operation, there is less stress on the batteries and the internal electronics.
- The air inlets, vents and fan should not be obstructed or blocked in any way. The more breathing space the system has, the cooler it operates.

- The air should remain free from excessive dust and chemical fumes.

- **Never use a Surge Protected device on the output of the system.**

Once a location has been selected and the unit is installed, it is ready for operation.

If used as an UPS, allow at least 24 hours, after the system is first installed, to fully charge the external batteries to a maximum state.

OPERATION

Once the system has been properly installed, it is ready to operate. The following procedures will explain how to start-up the system while plugged into rated electrical power and also how to start-up with no AC power available.

Normal Operation on AC Start-Up:

- Verify that the unit is plugged into properly rated electrical power.
- Plug in External Batteries to DC input.(if used as an UPS)
- Position the System Switch to the **ON** position.

The system will quickly beep three times.

AC Input LED will be Green.

Battery LED should be on Green if batteries are connected.

You will now have 120VAC available at the AC outlet.

- To turn off the load, press and hold the Load Button until the AC Out LED turns off. Approx. 2 seconds.

Battery Operation after AC Start-Up:

- Unplug the unit from the standard wall outlet.

The AC IN LED will turn Red.

An Audible beep will sound.

The Alarm LED will flash Red after approx. 10 seconds.

- To silence the Audible alarm, quickly press and release either the Cold Start or Load button.

If the unit is allowed to operate further, it will time out and shut off completely. If power were to return, the unit will automatically restart and return to the condition it was in at the moment it went into *Battery Mode*.

DC Start Operation (Cold Start)

If no utility power is available at the time backup power is required, the unit may be started to accomplish abbreviated tasks. The limitations of the battery prevent extended operations at full load.

- Position the System Switch to the **ON** position.
- Push and hold in the COLD START switch.

You now will have 120VAC available at the AC outlet.

Loading the System

The system can be loaded up to full rated load. If too much load is applied, the audible alarm will sound. If this increased load is not removed within a few seconds, the unit will discontinue output operation and latch into an alarm condition. The audible alarm will continue to sound and the ALARM LED will light. Reducing the load and cycling the System Power Switch **OFF** then **ON** can reset the system.

SIGNALS AND INTERFACING

There is one DB-9, subminiature, female connector and two USB Connectors. These connectors are provided for communications links to a computer or sophisticated monitoring device. Use the USB Type B connector when using the Clary Universal Traffic software which can be downloaded at www.Clary.com. See following page for USB setup instructions.

Below are the pin outs of the connectors with their default assignments:

DB9F CONNECTOR

- 1- **GP_OUT_1 (GENERAL PURPOSE OUTPUT 1)**
- 2- **RECEIVING DATA (RXD)**
- 3- **TRANSMITING DATA (TXD)**
- 4- **GP_OUT_2 (GENERAL PURPOSE OUTPUT 2)**
- 5- **SIGNAL GROUND**
- 6- **DATA SET READY (DSR)**
- 7- **REQUEST TO SEND (RTS)**
- 8- **UTILITY FAIL**
- 9- **LOW BATTERY**

USB TYPE B CONNECTOR

- 1- **VBUS**
- 2- **D- (DATA-)**
- 3- **D+ (DATA+)**
- 4- **GND**

USB SETUP

1. Contact Clary Corporation or your representative for latest software version.
 - SP560/SP1250LE Software
 - CDC_PCDriver
2. Connect the USB cable from your computer to the UPS's USB port (use the USB type B (Square) port).
3. Turn on the UPS.
4. Your computer will need a driver to connect for the first time. You should get a prompt as follows: Click on "No, not at this time" then "Next".



5. Select the "Install from a list or specific location" then click "Next"

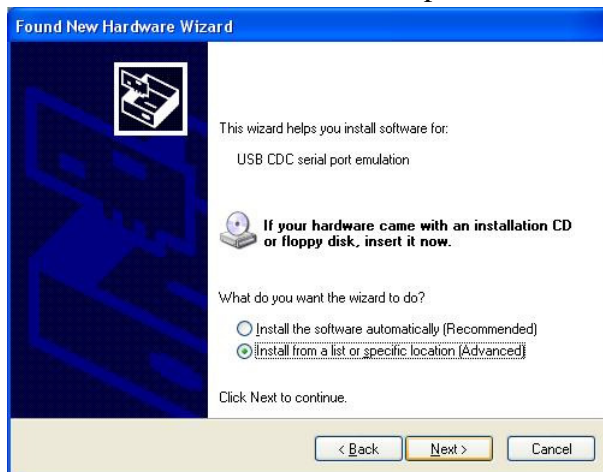

6. Select the “Include this location in the search:” then click “Browse”. Select the CDC_PCDriver Folder then click “Next”.

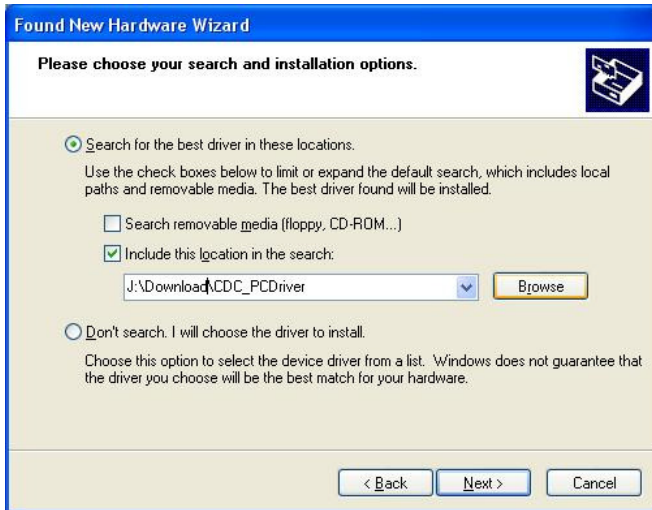

7. The driver will then be installed.

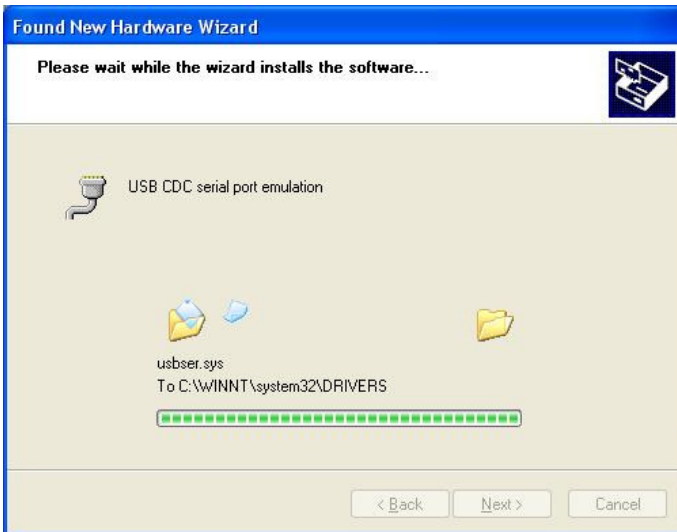

8. Driver is now installed. Click “Finish”.



9. Go to your device Manager, then click on the “Ports (COM & LPT)” tab. You will see the USB CDC serial port emulation (Com 1, 2, 3...etc.). This will be the com port assigned to your USB port. This is the Com port you will use when connecting to the Clary Software while using the USB port.

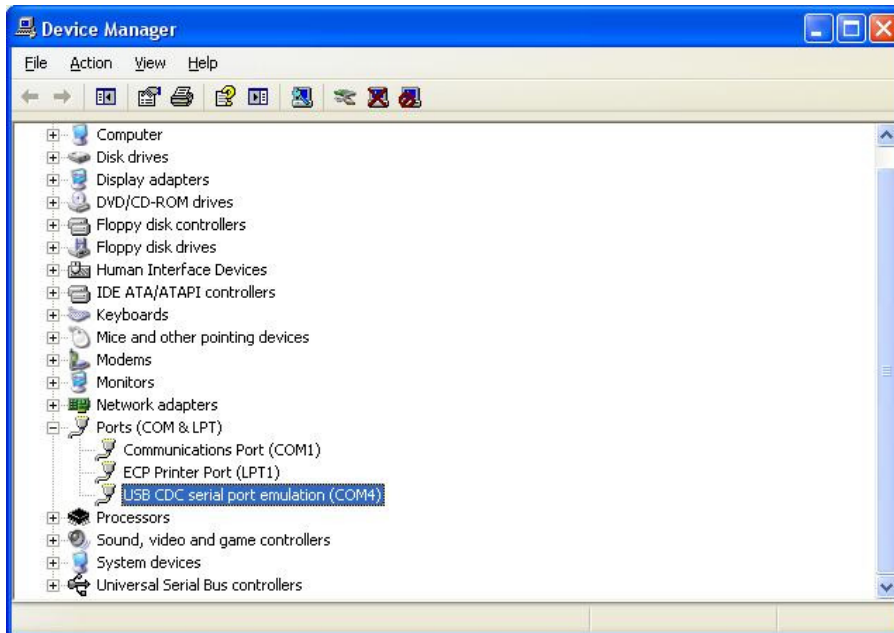

SPECIFICATIONS

ELECTRICAL

Input	
Voltage	120VAC 85VAC to 155VAC (without Battery discharge)
Frequency	45Hz to 65Hz
Output	
Voltage	120VAC \pm 3%
Frequency	50Hz or 60Hz \pm .25% (software selectable)
Current	SP560 4.8 A (400W / 570VA) SP1250LE 10.4A (875W / 1250VA)
Crest Factor Ratio (Non-linear load and less than 5% THD) Typical	@50% Load Up to 4.8:1 @75% Load Up to 3.2:1 @100% Load Up to 2.4:1
Harmonic Distortion	3%
Dynamic Response	\pm 4% for 100% Step Load Change, 0.5 Millisecond Recovery Time
Overload	110% for 10 min; 200% for 50 milliseconds
Efficiency (UPS)	85%
Load Power Factor	0.7
UPS Protection	Input and Output Short Circuit; Input and Output Overload; Excessive Battery Discharge

MECHANICAL

Input (Qty)	(1) IEC Inlet C14
Output (Qty)	SP560 (1) IEC Outlet C13 SP1250LE (2) IEC Outlet C13
Overall Dimensions W x D x H	SP560 11in x 8.5in x 1.7in SP1250LE 15.25in x 8.5in x 1.7in
Weight	SP560 5 lb. (2.3 kg) SP1250LE 8 lb. (3.6 kg)
Cooling	Low Velocity, Forced Air

CONTROLS AND INDICATORS

Visual Indicators	Battery Status, AC Output, Alarm, AC Input
Controls	Load On/Off, Cold Start
Intelligent Computer Interface	(1) DB9-F – RS232/Signal Interface (1) USB Type B

DESIGN

Standard Features	Regenerative On-Line, Sinewave Inverter Powers Load Continuously, Extended Brownout Protection, External Battery Connector, Digitally Controlled IGBT PWM, Power Factor Corrected on Input, Designed for Non-linear Loads
-------------------	---

ENVIRONMENTAL

Operating Temperature	-40°F to 165°F (-40°C to 74°C)
Humidity	0% to 95% non-condensing
Altitude	Sea Level to 10,000 Feet

BATTERY PACK (SP-48SB)

Use with SP560 Only

The SP48SB battery pack is used to provide back-up power to your equipment. The SP48SB provides 48V, 2.5Ah sealed lead batteries. You can add another battery pack in parallel to provide more runtime (dual battery cable needed). This battery pack is designed to be maintenance free.

There are also other battery options available to match the back-up time that is required for your needs. Please Contact your dealer for more information.

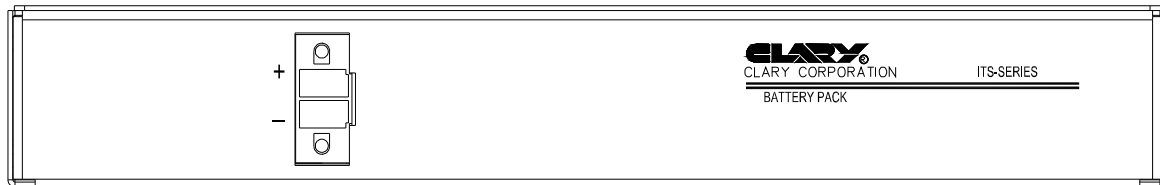

SPECIFICATIONS	
Voltage	48V
Capacity	2.5Ah
Runtime(Estimated)*	6 Min @ 400W, 17 min @ 200W
Overall Dimensions W x D x H	11in x 8.5in x 1.7in
Weight	10 lb. (4.5 kg)

*Estimated Runtimes are based on new batteries at 25C.

BYPASS BOX (SPH-302)

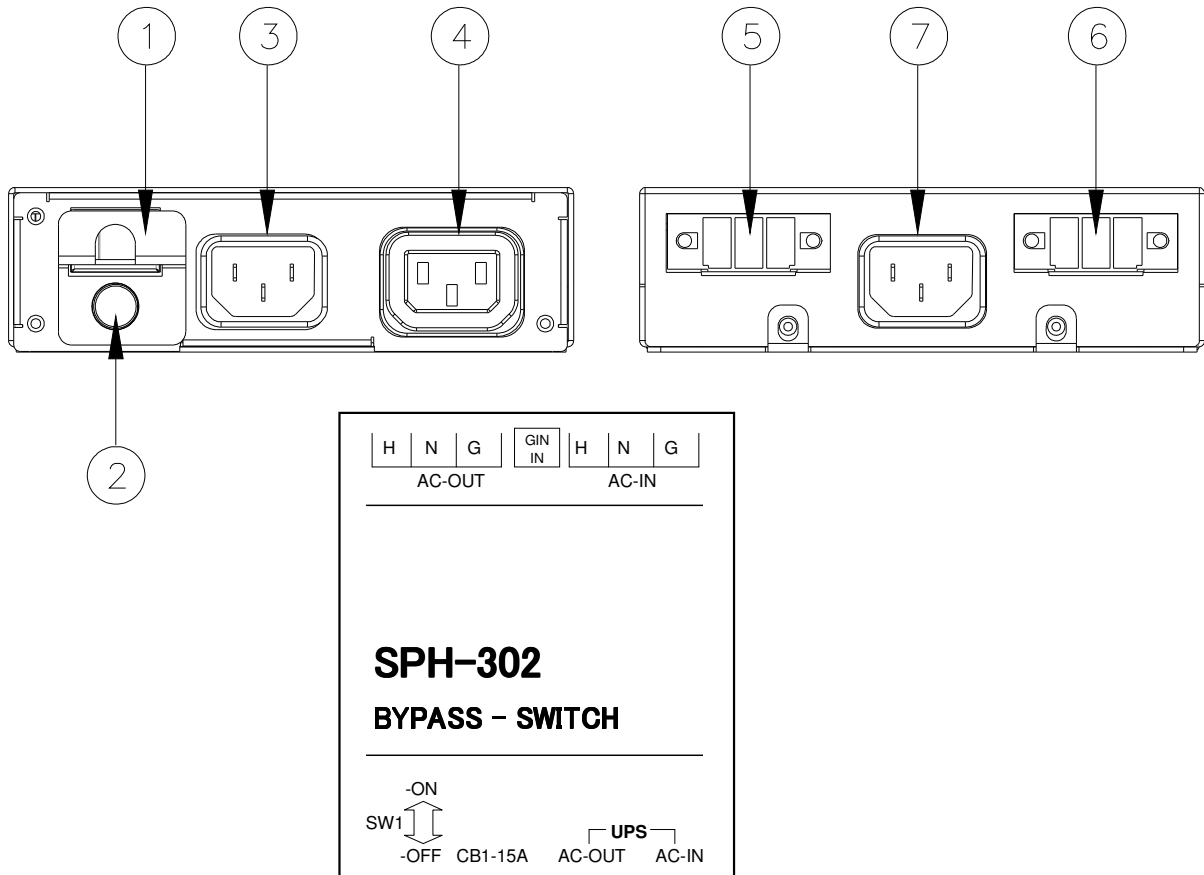

SPH-302 BYPASS BOX VIEW

- | | |
|---|--|
| <ul style="list-style-type: none"> 1 BYPASS SWITCH (SW1) 2 CIRCUIT BREAKER – 15A 3 UPS AC-OUT - IEC C14 4 UPS AC-IN – IEC C13 | <ul style="list-style-type: none"> 5 AC-IN – 3 Position Connector 6 AC-OUT – 3 Position Connector 7 GENERATOR IN – IEC C14 |
|---|--|

SPECIFICATIONS	
Voltage	120VAC
Current	30A in Bypass
Overall Dimensions W x D x H	5.25" x 7.50" x 1.75"
Weight	1 lb. (0.45 kg)

SUMMARY OF INDICATORS AND CONTROLS (SPH-302)

BYPASS SWITCH – When switch is in the “ON” Position, bypass box AC-Out will provide inverter power from the UPS as long as inverter power is available. If inverter power is not available, bypass power will be supplied at the output. When in the “OFF” position, Bypass power will be supplied to the output.

CIRCUIT BREAKER – A 15A resettable circuit breaker provides protection for the UPS AC-IN line.

UPS AC-OUT – IEC Inlet C14 type connects to the AC-OUT connector of the UPS.

UPS AC-IN – IEC Outlet C13 type connects to the AC-IN connector of the UPS.

AC-IN – A 3 position connector that connects to utility input. **Note: Must be connected to service with a protection fuse/circuit breaker no greater than 30A.**

AC-OUT – A 3 position connector that connects to your loads.

GENERATOR IN – IEC Outlet C13 type connects to a generator for backup power.

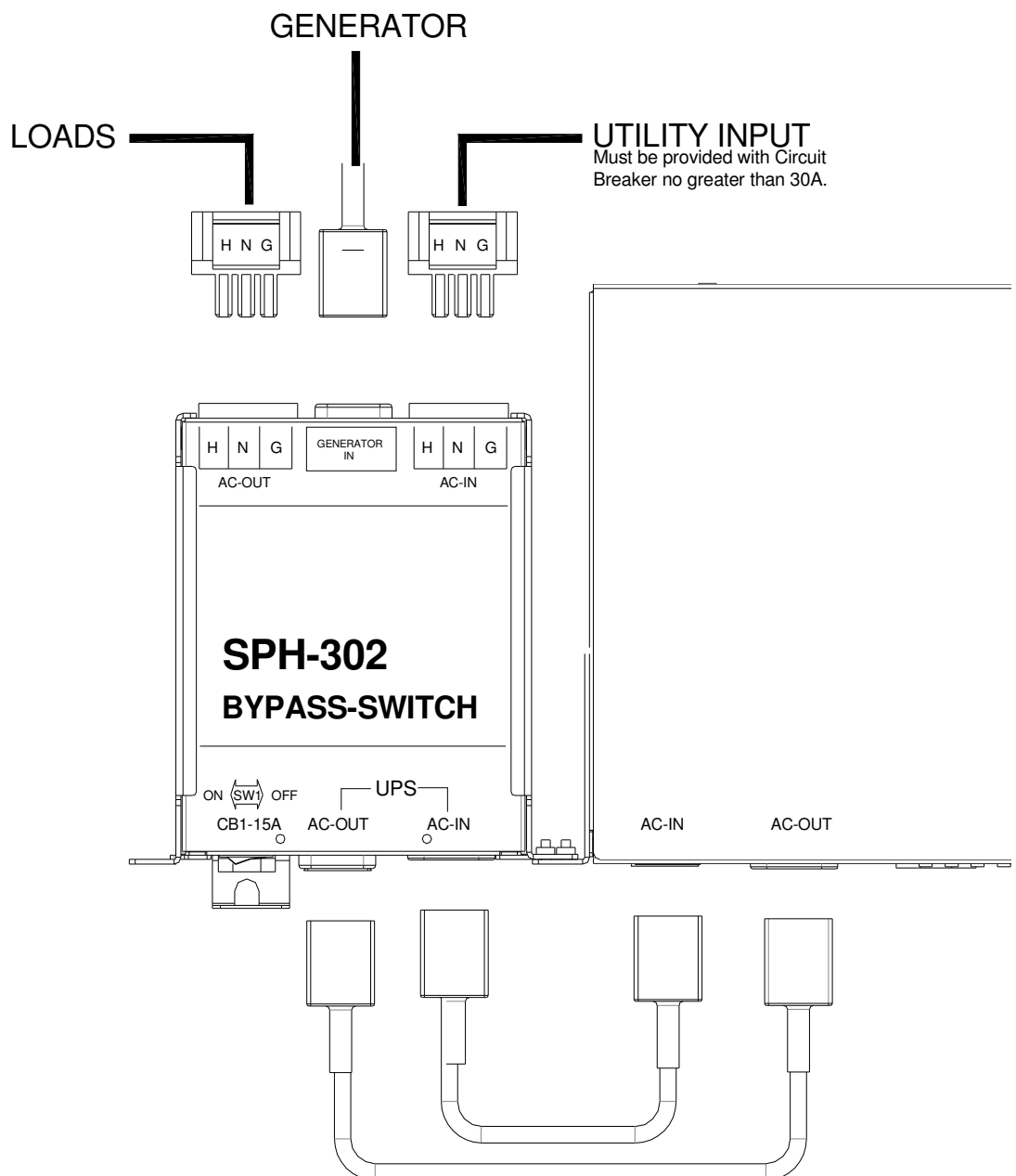

FAST CHARGER (SPLE-48)

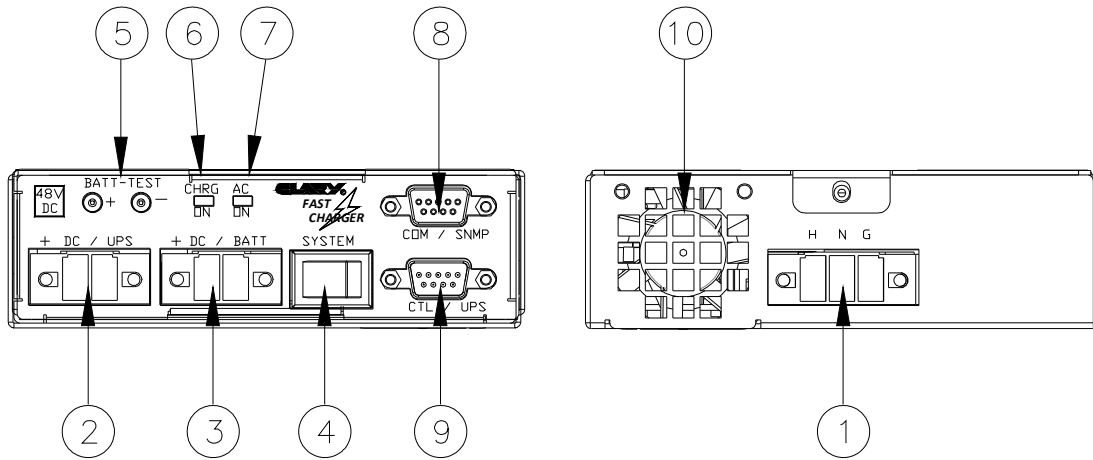

SPLE-48 FAST CHARGER VIEW

- | | | | |
|---|--------------------|----|--------------|
| 1 | AC INPUT 120VAC | 6 | CHGR ON LED |
| 2 | DC TO UPS | 7 | AC ON LED |
| 3 | DC TO BATTERY | 8 | COM PORT |
| 4 | SYSTEM SWITCH | 9 | CTL/UPS PORT |
| 5 | BATTERY TEST POINT | 10 | COOLING FAN |

SPECIFICATIONS	
Voltage (Input)	120VAC
Voltage (Output)	48VDC
Overall Dimensions W x D x H	5.25" x 7.50" x 1.75"
Weight	1 lb. (0.45 kg)

SUMMARY OF INDICATORS AND CONTROLS (SPLE-48)

AC INPUT – A 3 position connector that connects 120VAC input to power the fast charger.

DC/UPS – A 2 position connector that connects to the UPS DC-IN.

DC/BATT – A 2 position connector that connects to the 48VDC batteries.

SYSTEM SWITCH – Main switch that turns the charger ON/OFF.

BATT TEST – Test points to measure battery voltage.

CHRG ON – Indicates charger turned on.

AC ON – Indicates AC input present.

COM/SNMP – DB9 port to connect to SNMP or Computer.

CTL/UPS – DB9 port to connect to the UPS signal port. **Must be connected for charger to work.**

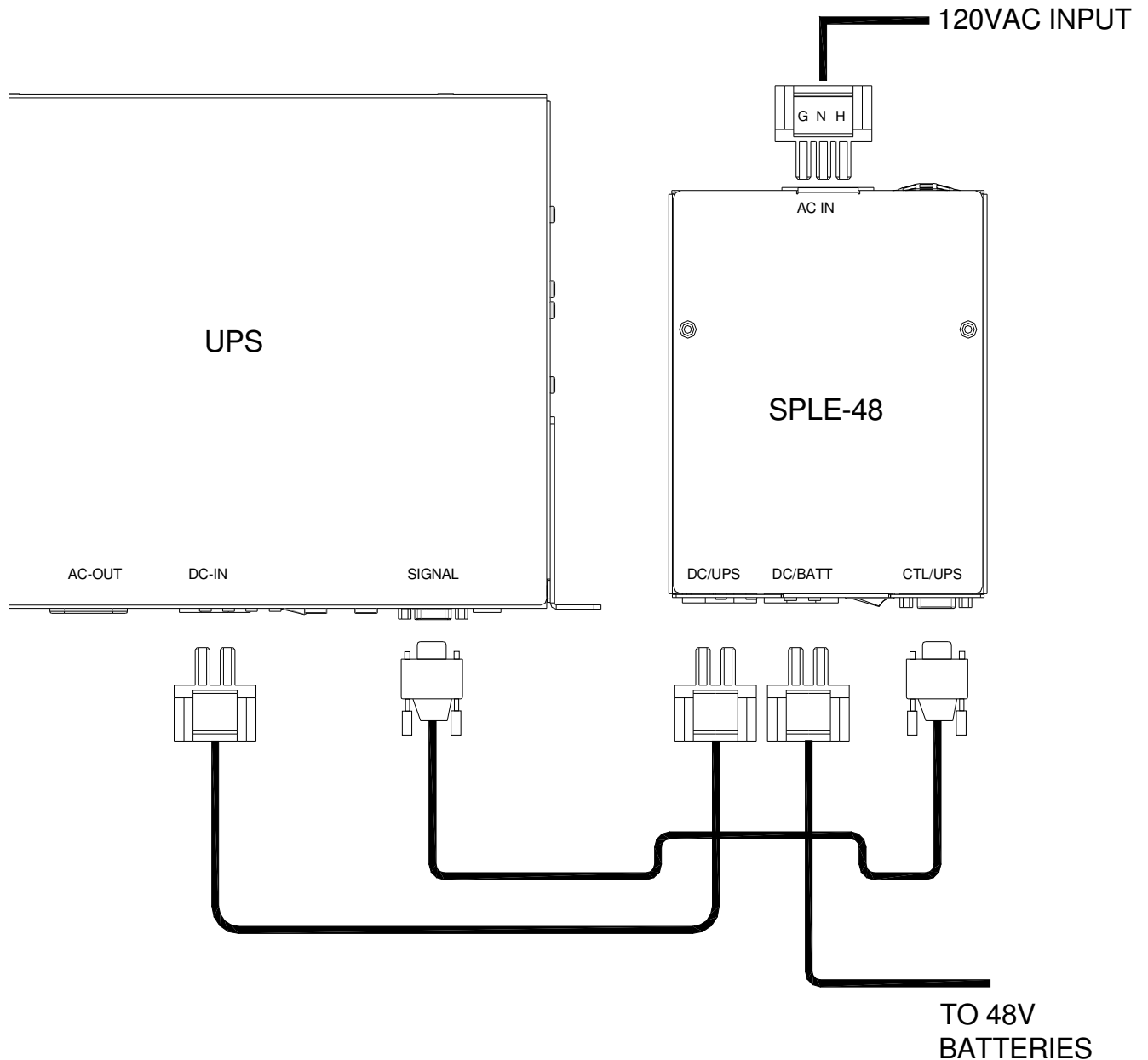

CARE AND MAINTENANCE

This device is designed to be maintenance-free. It can be cleaned with a damp cloth or nonabrasive cleanser.

WARNING: Do not use ACETONE-BASE cleaning solutions. Keep cleaning solutions out of the electrical receptacles on this device. Be sure filters, vents and fans are kept free from accumulation of dust, dirt or lint. Below is a simple maintenance schedule that will assist you in keeping the system at its peak level of performance and also minimizing potential premature failures.

Your system contains sealed maintenance-free batteries. When situated in the proper environment, with the proper charging and limited cycling, these batteries can last many years.

WARNING: Never attempt to service batteries. High voltage exists within the unit, which could cause electrical shock. Servicing of batteries should be performed or supervised by personnel knowledgeable of batteries and the required precautions. Keep unauthorized personnel away from batteries.

CAUTION - Do not dispose of battery or batteries in a fire. The battery may explode.

CAUTION - Do not open or mutilate the battery or batteries. Released electrolyte is harmful to the skin and eyes. It may be toxic.

CAUTION - A battery can present a risk of electrical shock and high short circuit current. The following precautions should be observed when working on batteries.

1. Remove watches, rings, or other metal objects.
2. Use tools with insulated handles.
3. Wear rubber gloves and boots.
4. Do not lay tools or metal parts on top of batteries.
5. Disconnect the charging source prior to connecting or disconnecting battery terminals.
6. Determine if the battery is inadvertently grounded. If inadvertently grounded, remove source of ground. Contact with any part of a grounded battery can result in electrical shock. The likelihood of such shock will be reduced if such grounds are removed during installation and maintenance.

The external rechargeable battery is recyclable. At the end of its useful life, under various state and local laws, it may be illegal to dispose of this battery into the municipal waste stream. Check with your local ordinances for details in your area for recycling options or proper disposal.

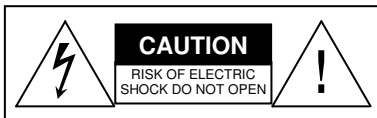

RECOMMENDED PREVENTATIVE MAINTENANCE SCHEDULE			
TIME	TASK	TOOLS REQ'D	INITIALS
Every 6 mo.	Test battery operation, check back-up time	None	
Every 12 mo.	Thoroughly clean unit	Vacuum, brush	
Every 42 mo.	Replace batteries	TBD	
Every 72 mo.	Replace cooling fan	Contact Dealer	

SERVICE AND REPAIR

Your **SP560/SP1250LE Series** UPS is backed by one of the finest customer service teams available. Write or call them at any time to obtain more information about your unit.

Clary Corporation
150 E. Huntington Dr.
Monrovia, CA 91016
1-800-551-6111

If a problem should occur, it is important that you obtain a Return Material Authorization (RMA) number from the Service Department to process any unit returned to the factory. In consulting the factory, always have the unit model number and serial number at hand. This information is located on the identification label and is essential in retrieving your unit's performance and history record.

The RMA number issued to you should appear on the outside of the carton, if the unit is returned, or on any correspondence regarding your unit. When shipping a unit back to the factory, try to use the original packing container and shipping materials. The Service Department cannot take responsibility for any unit damaged in return shipment. All units must be returned prepaid to:

Clary Corporation
SP Service Center
150 E. Huntington Dr.
Monrovia, CA 91016

WARRANTY

1. TIME AND SCOPE OF WARRANTY:

- 1.1. Clary Corporation hereby warrants parts shipped under this Agreement to be free from defective workmanship for a period of 2 years following date of shipment. Accidental damage, misuse or normal wear and tear shall not be construed as a defect.
- 1.2. The date of shipment as used herein will be the date on the Bill of Lading. If no Bill of Lading is issued the date of shipment shall be shown on seller's shipping document.
- 1.3. No provision of this warranty shall cover equipment that has been altered or modified from the original specifications to which it was manufactured unless authorized in writing.
- 1.4. No provision of this warranty shall cover batteries. However, battery manufacturer's warranties will be passed through to the customer whenever applicable.

2. LIMITS OF "IN WARRANTY" SERVICE LIABILITY:

- 2.1. Clary is obligated during the in-warranty period to provide service and/or adjustments to equipment returned to the factory at the expense of buyer (the term "factory" as used here-in shall also include any field service centers which may be established by Clary) and to repair or replace any part(s) thereof which in the opinion of authorized Clary personnel are found to have been defective.
- 2.2. Equipment requiring in-warranty services must be returned to the factory with all transportation charges prepaid, clearly tagged, and stating the nature of the trouble experienced, and the disposition of the equipment after repair. The equipment will be returned collect by Clary to the location specified via the best, least expensive carrier available or via customer's shipping instructions.
- 2.3. The nature of certain equipment installations may be such that it would be impractical or technically infeasible to remove the Clary portion of the equipment from the customer's premises to the Clary factory. In such cases, and at the request of the buyer, Clary will perform such service as can be satisfactorily rendered at buyer's location. The buyer will be charged only for travel expenses incidental to the service call, provided that the warranty is applicable.
- 2.4. During the in-warranty period, no service charges shall be payable by the buyer for service performed other than for service necessitated by accident, misuse, theft, abnormal line or source voltage fluctuations, abnormal conditions of operation, damage by the elements or damage resulting from adjustments, repairs, modifications made by other than Clary Authorized personnel, or the buyer's failure to reasonably maintain the equipment.
- 2.5. **THE FOREGOING WARRANTY IS EXCLUSIVE AND IS GIVEN AND ACCEPTED IN LIEU OF ANY AND ALL OTHER WARRANTIES, EXPRESSED OR IMPLIED, INCLUDING WITHOUT LIMITATION THE IMPLIED WARRANTIES OF MERCHANTABILITY AND FITNESS FOR A PARTICULAR PURPOSE. THE REMEDIES OF BUYER SHALL BE LIMITED TO THOSE PROVIDED HEREIN. IN NO EVENT WILL SELLER BE LIABLE FOR COLLATERAL OR CONSEQUENTIAL DAMAGES.** No person is authorized to assume in behalf of Clary any obligation or liability in connection with the sale, warranty or service policy of any products manufactured and/or marketed by Clary Corporation beyond the warranty description on the face hereof.

3. Clary Corporation reserves the right to make changes, additions, and/or improvements in its products without incurring any obligation to install them on its products previously sold.