

Owner's Operating Manual

GT SERIES CONTINUOUS POWER SYSTEM

MODELS COVERED:

GT1000

GT1250

GT1500

GT2000

GT2400

CLARY CORPORATION

150 E. Huntington Dr.

Monrovia, California 91016

Telephone ☎ 626-359-4486

☎ 800-44 CLARY

Fax. ☎ 626-305-0254

World Wide Web 🌐 [HTTP://WWW.CLARY.COM](http://WWW.CLARY.COM)

E-Mail 📧 SALES@CLARY.COM

Information contained herein is the property of Clary Corporation, is proprietary, confidential, and not to be disclosed, disseminated or used except for the purpose provided by

CLARY CORPORATION

TABLE OF CONTENTS

TITLE	PAGE
TABLE OF CONTENTS	2
INTRODUCTION	3
TECHNICAL DESCRIPTION	4
PACKAGING	6
PHYSICAL DESCRIPTION	7
SUMMARY OF INDICATORS AND CONTROLS	11
INSTALLATION	12
OPERATION	13
SIGNALS AND INTERFACING	14
SPECIFICATIONS	15
CARE AND MAINTENANCE	17
SERVICE AND REPAIR	18

INTRODUCTION

Congratulations! You have selected the highest quality protection for your *continuous power* needs. This unit offers a quiet and compact package with superior performance you can depend on. You now own a **GT Series Continuous Power System (CPS)** which is an all *Digital Technology* product manufactured by **Clary Corporation**, the first name in uninterruptible power system (UPS) reliability. The **GT** designation denotes a custom configuration offshoot from the standard **DT Series**. This means the addition of a step-up or step-down voltage conversion transformer for *global* applications. The *Continuous Power System* is the highest order in the hierarchy of UPS products. When power problems occur, there can be no compromising the reliability of your power solution. The **GT Series Continuous Power System** is your complete power solution.

This Users Manual is provided with your new **GT Series** unit. It will enhance your understanding of the product and its functions. Read this handbook carefully in the order it is presented prior to operating your unit. This will save you time and effort in your installation and application. The illustrations will also familiarize you with this unit's operating modes and indications. Always operate the unit within the guidelines and specifications given to maximize the unit's efficiency and lifetime. Also, your understanding of the product is essential in providing you years of service for your *continuous power* requirements.

This unit has been manufactured and tested to meet specific safety standards. It meets UL and FCC requirements and complies with safety performance standards.

IMPORTANT SAFETY INSTRUCTIONS, SAVE THESE INSTRUCTIONS

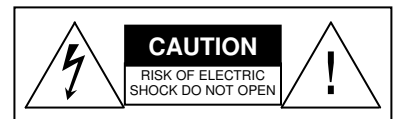
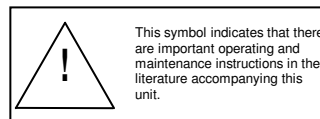
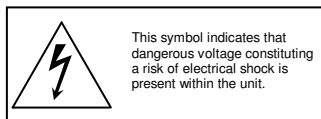

This manual contains important safety instructions that should be followed during installation and maintenance of the UPS and batteries. Be aware of the following symbols and their meaning as they appear throughout the manual:

This equipment generates and uses radio frequency energy and if not installed and used properly in strict accordance with the manufacturer's instructions, may cause interference to radio and television reception. All units in this manual have been tested and found to comply with the limits for a Class A computing device in accordance with the specifications in Subpart J of Part 15 of FCC Rules, which are designed to provide reasonable protection against such interference in a commercial installation. However, there is no guarantee that interference will not occur in a particular installation. If this equipment does cause interference to radio and television reception, which can be determined by turning the equipment off and on, the user is encouraged to try to correct the interference by one or more of the following measures:

- ☐ **Reorient the receiving antenna.**
- ☐ **Relocate the UPS with respect to the receiver.**
- ☐ **Move the UPS away from the receiver.**
- ☐ **Plug the UPS into a different outlet so that the UPS and receiver are on different branch circuits.**

If necessary, the user should consult the dealer or an experienced radio/television technician for additional suggestions. The user may find the following booklet prepared by the Federal Communications Commission helpful:

"How To Identify and Resolve Radio-TV Interference Problems"
This booklet is available from the U.S. Government Printing Office, Washington, DC 20402, Stock No. 004000003454.

TECHNICAL DESCRIPTION

The Digital Technology (GT) Series *Continuous Power System (CPS)* is a revolutionary new concept in total power protection and management. The GT Series is a microprocessor-based UPS that now allows the user to set most of the control feature parameters. By directly linking a personal computer to the GT Series RS232 port, frequency settings and operation, alarm signals, load switching, fan operation, etc. can all be programmed to meet specific application requirements.

The GT Series is a true on-line, continuous power UPS. In the tradition of Clary products, the GT Series generates the same high quality and proven reliability to provide the best power protection available for today's critical applications.

In keeping with state-of-the-art design, the power electronics are completely governed by an on-board microprocessor. Given the powerful memory capability of today's microcontrollers, this microprocessor has evolved the UPS into an all-in-one complete power distribution and monitoring center. Not only is your critical load insured of the most reliable and constant power available, but the user may now continuously track status of the supply components that keep the entire system operational. Production downtime can now be virtually eliminated by knowing exactly what patterns the supply utility power maintains and by knowing exactly the condition and life expectancy of the battery reserve.

Reference the block diagram for a simplified explanation of the system's operation. The AC utility source is connected to the power and micro-electronics when the input switch is closed. The input line is filtered, power factor corrected and rectified for enhanced performance without disturbing other equipment that may share the same utility circuit. In **GT** units, a step-down, input isolation transformer is added to accept a wide range of input voltages for global applications. Output transformers, SNMP adapters and many other options are available.

The microprocessor controls an *Inverter Generator* that produces a low harmonic, AC sinewave for continuous power applications.

When the input AC utility line fails, the battery circuit within this system takes over to ensure continuous power. Only after properly rated power is returned, does the microprocessor reconnect the input source back into the system.

The microprocessor is directly tied to an external RS232 connector port. This allows the user to monitor and even set some of the operating parameters. With a simple link to a personal computer using the **DT-UPS2** software program, you can actually view, on your monitor, the event history of the power distribution system with the **GT Series** unit as the central hub. More sophisticated users may implement the optional SNMP package to accomplish full *Network Power Management*.

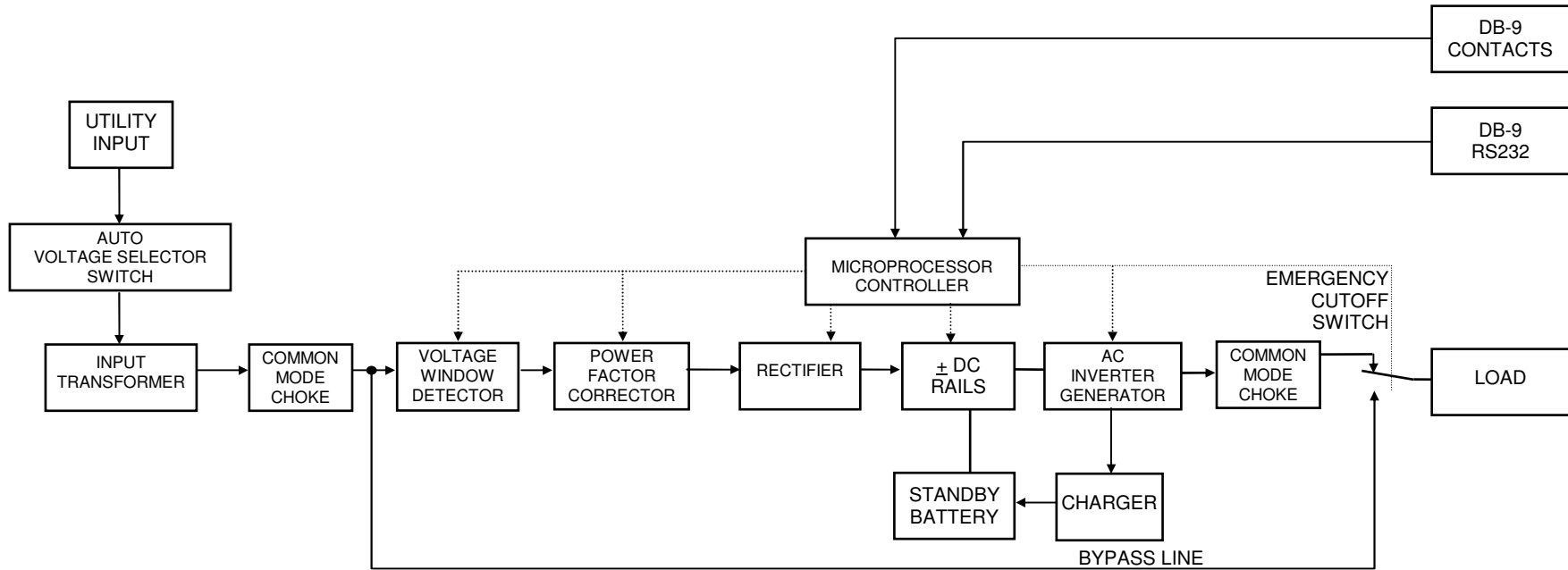
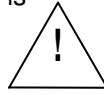

FIGURE 1: GT SERIES BLOCK DIAGRAM

PACKAGING

Your UPS has been carefully packaged to withstand most abuse sustained during shipment. The packing material has been specifically designed to protect this system for normal handling, using most shipping carriers. If there is significant damage to the carton, or if there is any physical damage to this unit, report this to your carrier.

These units are encapsulated in a protective wrap that comes apart once the product is removed from



the shipping carton. Save all packing material for future use.

Take extra precaution when removing or returning it to the box. Because this unit contains a battery, it can be quite heavy. Never attempt to unpackage the equipment unassisted.

The packaging also contains important information on use and care as well as valuable warranty information. Read all materials before storing this literature with your other valuable product documents.

PHYSICAL DESCRIPTION

This section will point out and illustrate the various indicators, functions and controls of the **GT Series** UPS. Pictured is the front view of the system, then followed by the rear view. The important attributes of the **GT Series** unit are numbered to assist you in locating them on your machine and also to fully explain its function and how it relates to system operation.

Numbers on the drawing will correspond to the operating component's name at the bottom with a brief identification. In the next section, a complete explanation of all numbered items will be enhanced to ensure you have a full understanding of the operation of this system.

Visual indicators used on the front panel are long lasting, very efficient, light emitting diodes (LED). When operating the push-button switches, always hold the switch in for at least two seconds to insure function confirmation. This feature has been implemented into the system design to avoid inadvertent operation of any of the user-available functions.

The rear panel has been engineered with the user's multiple applications in mind. In some models, two of the output receptacles have been rotated to allow attachment of a plug-in transformer without hanging over the back of the unit or interfering with another outlet. Two load outputs are provided with two or three receptacles per output. The outputs can be independently switched on or off.

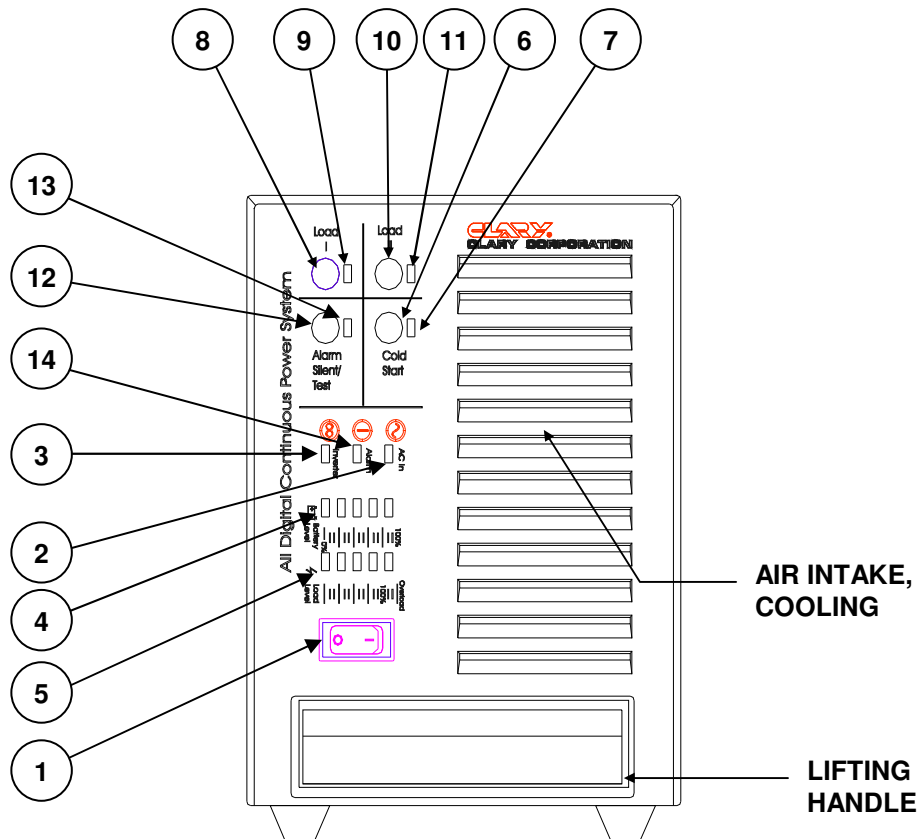

FIGURE 2: FRONT VIEW, GT1000

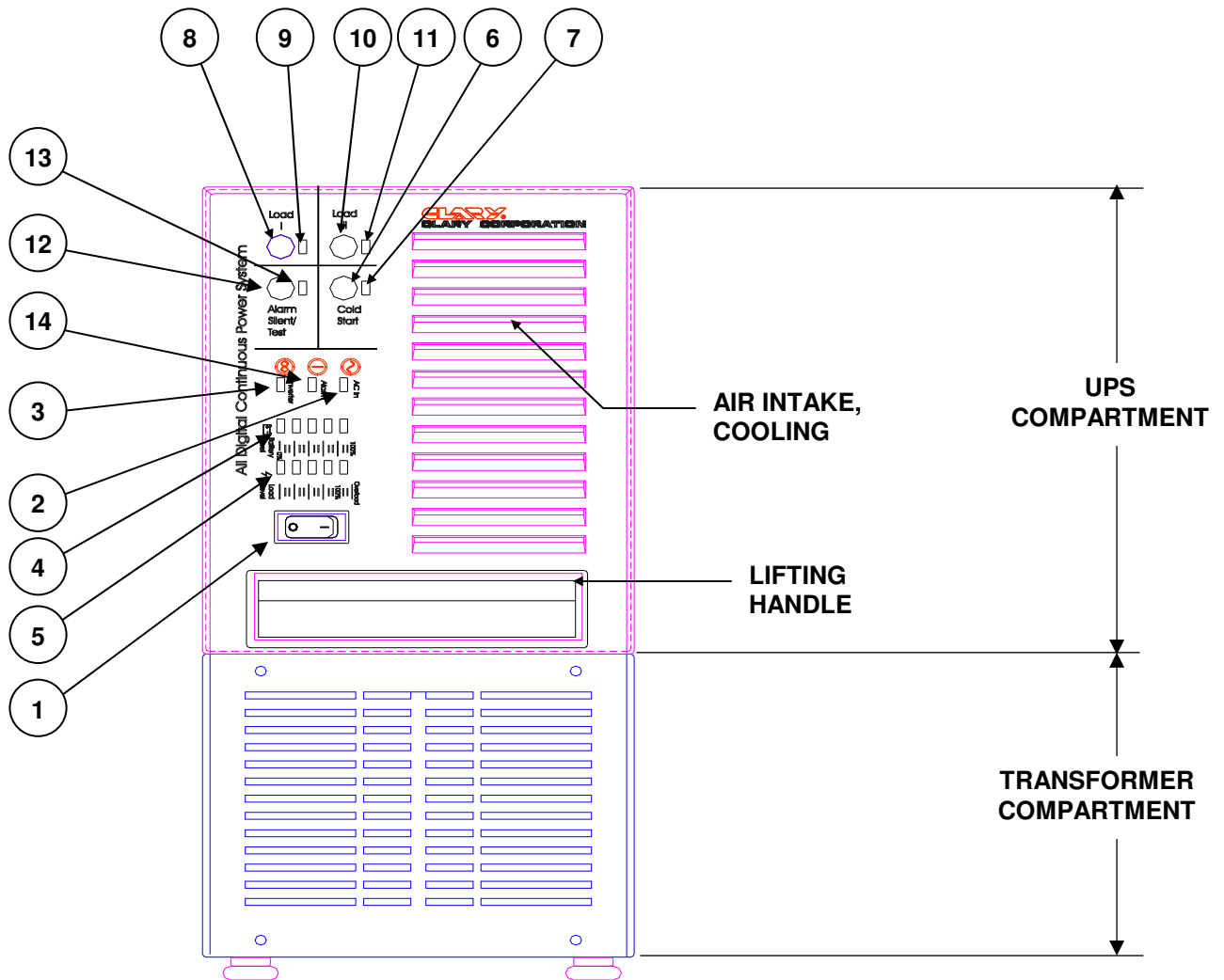

FIGURE 3: FRONT VIEW, GT1250 – GT2400

GLOBAL FRONT PANEL CALLOUTS

- | | |
|---|--|
| <p>1 SYSTEM POWER SWITCH</p> <p>2 AC In - Input line indicator</p> <p>3 Inverter - Inverter operating indicator</p> <p>4 Battery Level - Charge/discharge indicators</p> <p>5 Load Level - Output capacity indicators</p> <p>6 Cold Start - DC start switch</p> <p>7 COLD START ACKNOWLEDGE INDICATOR</p> <p>8 Load I - Enable switch for a row of output receptacles</p> | <p>9 LOAD I ACKNOWLEDGE INDICATOR</p> <p>10 Load II - Enable switch for a row of output receptacles</p> <p>11 LOAD II ACKNOWLEDGE INDICATOR</p> <p>12 Alarm Silent/Test - Dual function switch</p> <p>13 ALARM SILENT/TEST ACKNOWLEDGE INDICATOR</p> <p>14 Alarm - Fault indicator</p> |
|---|--|

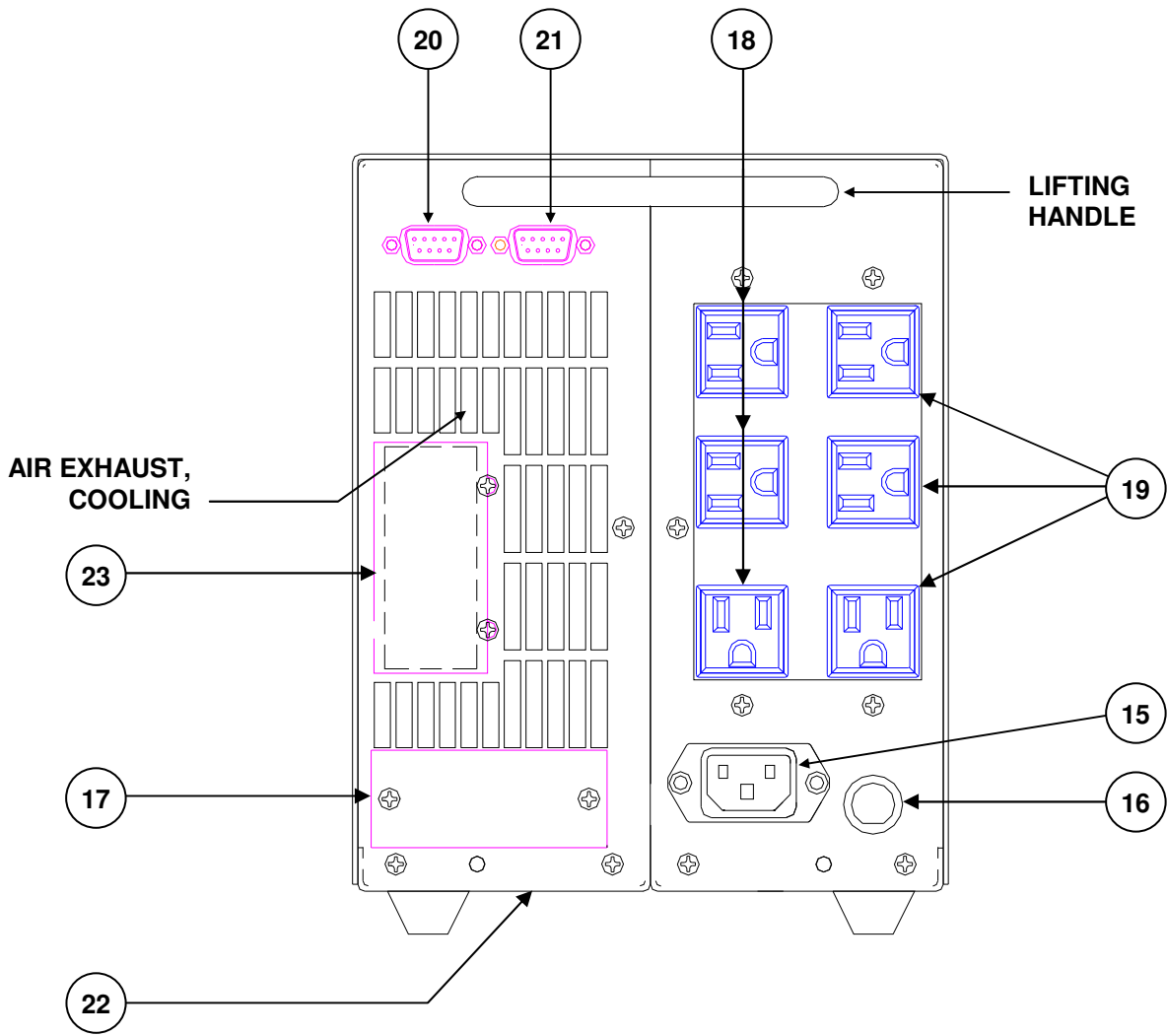

FIGURE 4: REAR VIEW, GT1000

GLOBAL REAR PANEL CALLOUTS

- | | |
|---|--|
| <p>15 INPUT - AC Line cord inlet</p> <p>16 INPUT LINE FUSE – Input line protection</p> <p>17 DC INPUT - Auxiliary battery connector</p> <p>18 120VAC OUTPUT (LOAD 1)- System output, left row</p> | <p>19 120VAC OUTPUT (LOAD 2)- System output, right row</p> <p>20 SIGNAL - Open-collector signal contacts</p> <p>21 RS232 - Computer communications signals</p> <p>22 IDENTIFICATION LABEL</p> <p>23 SNMP – (Optional) Slot for network monitoring</p> |
|---|--|

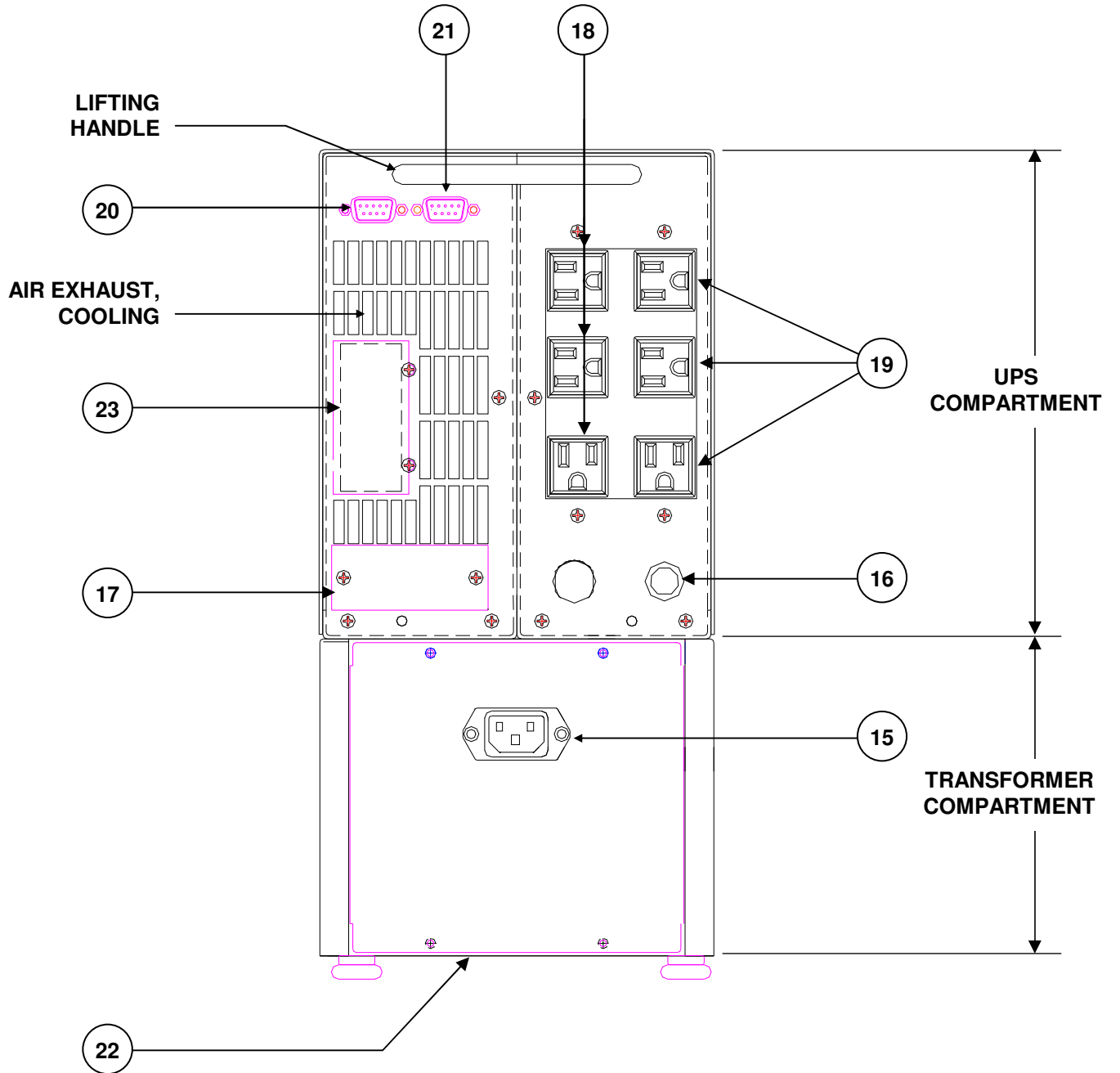

FIGURE 5: REAR VIEW, GT1250 – GT2400

SUMMARY OF INDICATORS AND CONTROLS

SYSTEM POWER SWITCH - The main control switch that engages utility power to the entire unit. By activating this switch it initializes normal operation.

AC In - The utility input indicator that identifies status of the line voltage. If the line voltage is within the specified range, it will remain lit. If the AC input is out of range, this indicator will flash in 1 to 2 second intervals.

Inverter - This indicator identifies the status of the regenerated, conditioned protected output power. This indicator will stay **ON** as long as protected power is available from the power inverter generator.

Battery Level - This is the battery status bar graph. During normal operation, this bar graph will show the charging of the battery; all indicators lit will represent a fully charged battery. During battery operation, this bar graph represents a discharge meter indicating less battery time available as each light goes **OFF**.

Load Level - This is the system output capacity status bar. The number of lights on the graph indicate an approximate percentage of system full load. All lights being **ON** would indicate full load.

Cold Start - A momentary push-button switch to activate the system in the event no utility power is available. The system will be allowed to start up by using power from its internal battery. Depress this switch, the indicator above it will light, and hold it in until the audible alarm beeps once. The system will maintain a load depending upon the condition of the battery.

Load I - A momentary push-button switch that toggles the output LOAD I AC output terminals at the rear panel. Unless the unit is powered up using the Cold Start switch, the output load will normally be connected to the inverter generator output. The indicator above the switch will be **ON** to represent this. Depressing the switch can disconnect the output. While the switch is depressed, the indicator will blink to represent transition. Once the indicator stops blinking, the switch can be released for a successful transition.

Load II - A momentary push-button switch that works identical to LOAD I except it corresponds to the LOAD II AC output terminals at the rear panel.

SNMP - (Optional) A slot available to install an interface card to provide system network management.

Alarm Silent/Test - A momentary push-button switch that controls two different functions depending on the mode of operation. In the normal mode of operation, if this switch is depressed and held in, the above indicator will blink. Once it stops blinking, the unit will perform an internal 1 to 2 minute battery check. Once the test is completed, if the battery is below standards, the system will indicate that the battery needs replacing. The system will not run this battery test unless the battery is detected to be fully charged. During battery or abnormal operation, an audible alarm will accompany this mode. By depressing this switch, the adjacent indicator will blink. When it stops blinking, the alarm will be silenced. Once the fault or reason for the alarm is corrected, this audible alarm condition will automatically reset. The audible alarm can be re-enabled during abnormal conditions by pressing and holding the switch again.

NOTE - All switches must be held in for at least two seconds to engage their function. This is to prevent any inadvertent switch operation.

Alarm - This is a fault indicator that will light in the event that the inverter generator is non-operable. This could be due to an overtemperature situation or an inverter malfunction.

INPUT - An IEC inlet is provided for universal input cord connections.

FUSE - The power protection device for the input circuitry.

DC INPUT - The auxiliary battery input connector to add optional batteries for extended backup time.

120VAC OUTPUT (Load I & Load II) - The output groupings that can be independently controlled by the corresponding front panel switch. During normal operation, inverter generator power is supplied at these outlets. Three separate hardwire circuits have been provided. They are individually protected by circuit breakers.

SIGNAL - A DB-9 subminiature, female connector that outputs the open-collector signal contacts that generate a low state during *utility interrupt*, *low battery* and *inverter off* conditions.

RS232 - A DB-9 subminiature, female connector that outputs true RS232 computer communications signals.

IDENTIFICATION LABEL - The model number and serial number of the system is located here. This label is located on the underside of the unit. Always refer to this information when corresponding with the factory.



INSTALLATION

If the unit is to be stored, it is recommended to refresh the internal battery at least once every 90 days. To do this, plug the system in, position the power On/Off switch to "ON" and allow the unit to idle for at least 24 hours.

The **GT** unit is designed for installation in a protected environment. Some important points to consider when positioning a unit for operation:

- A properly rated (preferably dedicated) outlet is accessible for the six-foot power cord, supplied with the unit. It is not recommended to modify the supplied cord in any way nor should an extension cord of any kind be used.
- The cord paths in the system installation should remain clear of foot traffic or anything else that may disturb permanent connection.
- The installation site should maintain an ambient air temperature of less than 104°F (40°C). When the

environment for the system remains cooler during operation, there is less stress on the batteries and the internal electronics.

- The air inlets, vents and fan should not be obstructed or blocked in any way. The more breathing space the system has, the cooler it operates.
- The air should remain free from excessive dust and chemical fumes.

Once a location has been selected and the unit is installed, it is ready for operation.

Allow at least 8 hours, after the system is first installed, to fully charge the internal battery to a maximum state.

OPERATION

Once the system has been properly installed, it is ready to operate. The following procedures will explain how to start-up the system while plugged into rated electrical power and also how to start-up with no AC power available.

Normal Operation on AC Start-Up:

- Verify that the unit is plugged into properly rated electrical power.
- Position the System Power Switch to the **ON** position.

The system will proceed through about a three-second diagnostic where all the lights will sequence **ON** then **OFF**. The AC IN light will flash several times and the audible alarm will give a short burst. The AC IN light will then stay **ON** and the battery level meter will light to at least an 80% level. The INVERTER light will come **ON**, and power will be available at all the output receptacles. The LOAD I and LOAD II will come **ON**.

Actual load may be connected at any time during this procedure, however, power is only available when the light above either of the LOAD switches is **ON** continuously.

Battery Operation after AC Start-Up:

- Unplug the unit from the standard wall outlet. The AC ON light will flash at two to three second intervals. Within 5 seconds, the audible alarm will sound at half-second intervals.
- Push and hold in the ALARM SILENT/TEST switch until the audible alarm is inhibited.

If operation were to continue in this mode, the BATTERY LEVEL meter would start to turn **OFF**, one light at a time starting from the top. Once the last light is left and the preprogrammed battery availability time (usually about 2 minutes) is reached, the alarm will sound in a constant tone. Had the alarm been previously silenced, it would still re-enable to alert the user of limited operation. This alarm can also be silenced as before. If the unit is allowed to operate further, it will time out and shut off completely. If power were to return, the unit will automatically restart and return to the condition it was in at the moment it went into *Battery Mode*.

DC Start Operation (Cold Start)

If no utility power is available at the time backup power is required; the unit may be started to accomplish abbreviated tasks. The limitations of the battery prevent extended operations at full load.

- Position the System Power Switch to the **ON** position.
- Push and hold in the COLD START switch until the audible alarm beeps.

The unit will start up similarly to normal AC start-up except the AC IN LED will continue to flash. The LOAD outputs will come up in the **OFF** mode when using the COLD START feature.

Loading the System

The system can be loaded up to full rated load. As load is applied, the LOAD METER will start to turn **ON**. Once full load is achieved, the full LOAD METER should be lit. As additional load is applied, the top red OVERLOAD LED will come **ON**. If too much overload is applied, the audible alarm will sound. If this increased load is not removed within five seconds, the unit will discontinue output operation and latch into an alarm condition. The audible alarm will continue to sound and the ALARM LED will light. Reducing the load and cycling the System Power Switch **OFF** then **ON** can reset the system.

Programming the Outputs:

The outputs on startup can be programmed **ON** or **OFF**. The default mode is programmed to turn both load circuits **ON** whenever you power up the UPS on AC startup. They will stay energized until you turn **OFF** the UPS, the batteries run down during a power outage or if the appropriate load button is pressed.

To program both loads to be **OFF** when the UPS is turned **ON**:

- Turn the UPS **OFF**.
- Turn the UPS **ON** while pressing and holding the ALARM SILENT/TEST switch.
- The UPS will come **ON** with both loads **OFF** and will remember this setting each time the unit is turned **ON**.

To program both loads to come **ON**:

- Turn the UPS **OFF**.
- Turn the UPS **ON** while pressing and holding both LOAD I and LOAD II switches (this definitely requires both hands). The UPS will remember this combination the next time it is powered **ON**.

To program LOAD I or LOAD II to come **ON** individually at startup:

- Turn the UPS **OFF**.
- Turn the UPS **ON** while pressing and holding either LOAD I or LOAD II switches.

The UPS will remember this combination the next time it is powered **ON**.

SIGNALS AND INTERFACING

At the rear of the unit are two DB-9 subminiature, female connectors. These are provided for communications links to a computer or sophisticated monitoring device. SIGNAL provides open-collector outputs that typically signal *Utility Interrupt* and *Low Battery* conditions. A system shutdown feature is also available on this port. Applying a short between Pin 6 and Pin 7 will cause the system to shutdown in battery mode. This conserves the battery life once

an orderly shutdown has been accomplished. The system may be configured to shutdown by applying a +5 to +12V signal across the appropriate pins. Contact the factory for configuration details. RS232 is a true computer communications signal port.

The open-collector signal outputs can be converted to dry contact closures, as an option. Below is the pin out of the two connectors with their default assignments:

OPEN-COLLECTOR CONNECTOR (SIGNAL)

- 2- UTILITY INTERRUPTED SIGNAL
- 4- COMMON SIGNAL RETURN
- 5- LOW BATTERY SIGNAL
- 6- + UPS SHUTDOWN
- 7- - UPS SHUTDOWN

RS232 CONNECTOR

- 2- TRANSMITTING DATA (TX)
- 3- RECEIVING DATA (RX)
- 6 & 8- DATA SET READY
- 5- SIGNAL GROUND

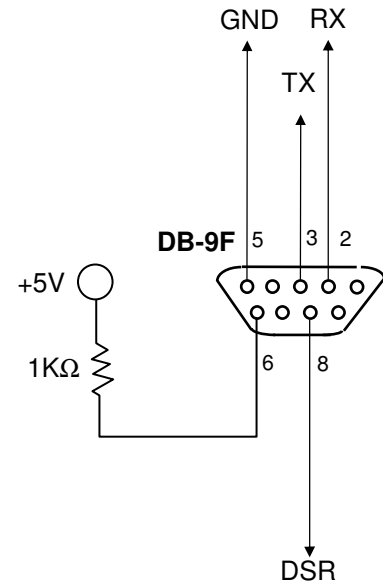

RS232 CONNECTOR

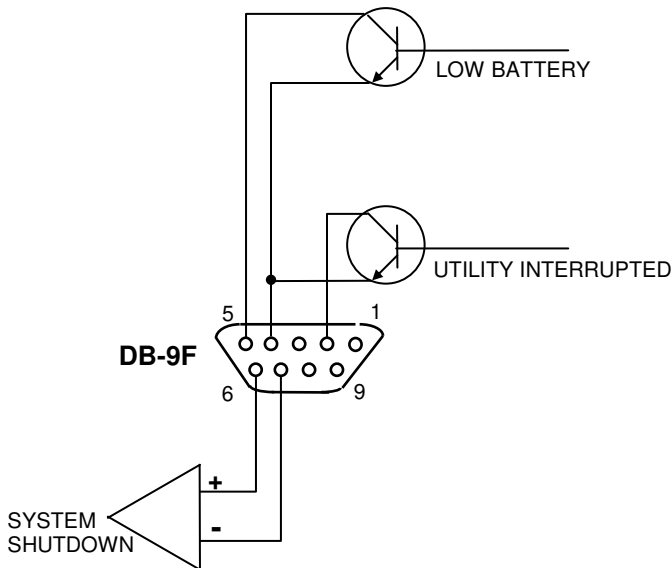

SIGNAL: OPEN-COLLECTOR CONTACT CONNECTOR

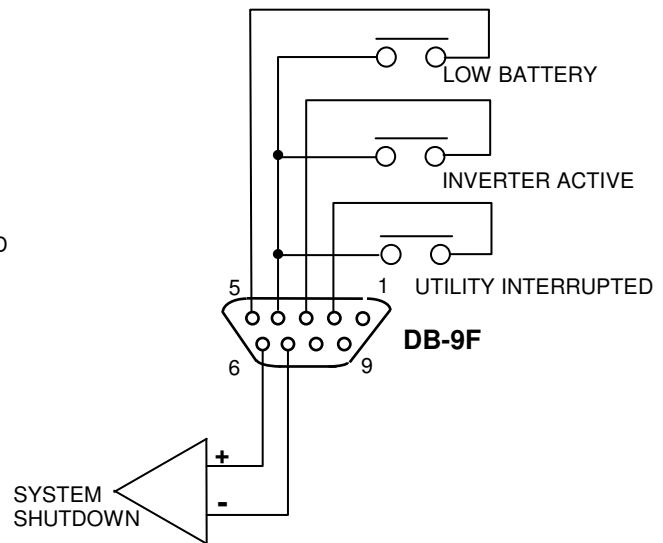

SIGNAL: DRY CONTACT CLOSURE (OPTION) CONNECTOR

SPECIFICATIONS

ELECTRICAL

Input

Voltage (Auto-selectable)	120VAC or 220VAC or 240VAC +10%, -20% (without Battery discharge)
Power Factor Corrected	/AW MIL STD. 1399 Sec. 300
Frequency	45 to 65Hz
Current	See Model Selection Guide

Output

Voltage	120VAC \pm 3%
Frequency	50Hz / 60Hz (software select) Line Sync (software select)
Current	See Model Selection Guide
Crest Factor Ratio (Non-linear load and less than 5% THD) Typical	@50% Load Up to 4.8:1 @75% Load Up to 3.2:1 @100% Load Up to 2.4:1
Total Harmonic Distortion (THD)	3% Typ; 5% Max. (@100% Non-linear load)
Dynamic Response	\pm 4% for 100% Step Load Change, 0.5 Millisecond Recovery Time
Overload	110% for 10 Minutes; 200% for 50 milliseconds
Efficiency (UPS)	88% Typ.
Battery Back-up	See Model Selection Guide
UPS Protection	Input and Output Short Circuit; Input and Output Overload; Excessive Battery Discharge

ENVIRONMENTAL

Operating Temperature	32°F to 104°F (0°C to 40°C)
Humidity	0% to 95% Non-condensing
Altitude	Sea Level to 10,000 Feet
Audible Noise	39-42 dBA at Five Feet

MECHANICAL

Input Inlet (6' Line Cord Provided)	IEC 320
Output (Qty.)	(6) NEMA Type 5-15R
Cooling	Low Velocity, Temperature Controlled Reversible Forced Air
Dimensions	See Model Selection Guide
Weight	See Model Selection Guide

DESIGN

Standard Features	Power Factor Corrected, Digital Regenerative™ On-Line, Sinewave Inverter Powers Load Continuously Extended Brownout Protection Designed for Non-linear Loads Continuous Operation on -20%,+12% Line Automatic Bypass RS232 Data Interface Software Selectable Output Frequency AC Output Switch Auxiliary Battery Connector Optional SNMP Interface
Specifications	UL Design FCC Class A IEEE 587/ANSI C62.41
MTBF	In Excess of 100,000 Hours
Typical Recharge Time to 85% Capacity at 100% Load	8 Hours

CONTROLS AND INDICATORS

Visual Indicators Sequenced LEDs Single LED	Battery Level, Load Level AC Input, Inverter On, Fault Fault Silent, AC Output, Cold Start, Replace Battery
Front Panel Controls	Power On, Cold Start Fault Silence, Battery Test AC Output On/Off
Audible Alarms	Utility Interrupt, Inverter Failure Overload, Low Battery
RS232 Data Interface (DB-9F)	Full Interactive, Remote Computer Monitoring and Control of UPS Functions. Compatible with Systems Enhancement UPS Monitor & Control Software
Open-Collector (DB-9F)	Allows Alarm Function Monitoring
Optional SNMP Interface (RJ45)	Allows Full Control and Monitoring Over Network Connection.

Specifications subject to change without notice. 7/99

MODEL SELECTION GUIDE					
DESCRIPTION	MODEL NUMBER				
	GT1000	GT1250	GT1500	GT2000	GT2400
Nominal VA (Max Watts)	1000 (700)	1250 (875)	1500 (1050)	2000 (1400)	2400 (1680)
Input Current Amps (@120VAC)	7.2	8.8	10.7	14.3	17.4
Output Current Amps	8.3	10.4	12.5	16.7	20
Input Plug (Standard) NEMA Type	5-15P	5-15P	5-15P	5-20P	5-20P
Battery Backup Time Minutes @100%/@50% Load	5/17	7/21	5/17	5/18	4/14
Weight lbs(kg)	55 (25)	80 (36)	80 (36)	100 (45)	100 (45)
Dimensions HxWxD in(cm)	9.1(23) x 6.9(17.5) x 21(53)		14.1(36) x 6.9(17.5) x 21(53)		

CARE AND MAINTENANCE

This device is designed to be maintenance-free. It can be cleaned with a damp cloth or nonabrasive cleanser.

WARNING: Do not use ACETONE-BASE cleaning solutions. Keep cleaning solutions out of the electrical receptacles on this device.

Be sure filters, vents and fans are kept free from accumulation of dust, dirt or lint. Below is a simple maintenance schedule that will assist you in keeping the system at its peak level of performance and also minimizing potential premature failures.

Your system contains sealed maintenance-free batteries. When situated in the proper environment, with the proper charging and limited cycling, these batteries can last many years.

WARNING: Never attempt to service batteries. High voltage exists within the unit which could cause electrical shock. Servicing of batteries should be performed or supervised by personnel knowledgeable of batteries and the required precautions. Keep unauthorized personnel away from batteries. When replacing batteries, use the same number and type batteries.

CAUTION - Do not dispose of battery or batteries in a fire. The battery may explode.

CAUTION - Do not open or mutilate the battery or batteries. Released electrolyte is harmful to the skin and eyes. It may be toxic.

CAUTION - A battery can present a risk of electrical shock and high short circuit current. The following precautions should be observed when working on batteries.

1. Remove watches, rings, or other metal objects.
2. Use tools with insulated handles.
3. Wear rubber gloves and boots.
4. Do not lay tools or metal parts on top of batteries.
5. Disconnect the charging source prior to connecting or disconnecting battery terminals.
6. Determine if the battery is inadvertently grounded. If inadvertently grounded, remove source of ground. Contact with any part of a grounded battery can result in electrical shock. The likelihood of such shock will be reduced if such grounds are removed during installation and maintenance.

The internal rechargeable battery is recyclable. At the end of its useful life, under various state and local laws, it may be illegal to dispose of this battery into the municipal waste stream. Check with the factory for details in your area for recycling options or proper disposal.

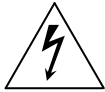

RECOMMENDED PREVENTATIVE MAINTENANCE SCHEDULE			
TIME	TASK	TOOLS REQ'D	INITIAL <input checked="" type="checkbox"/>
Every 6 mo.	Test battery operation, check back-up time	None	
Every 12 mo.	Thoroughly clean unit	Vacuum, brush	
Every 42 mo.	Replace battery	3/8 Hex Nut Driver	
Every 72 mo.	Replace cooling fan	Screwdriver	

SERVICE AND REPAIR

Your **GT Series** UPS is backed by one of the finest customer service teams available. Write or call them at any time to obtain more information about your unit.

Clary Corporation
150 E. Huntington Dr.
Monrovia, CA 91016
1-800-551-6111

If a problem should occur, it is important that you obtain a Return Material Authorization (RMA) number from the Service Department to process any unit returned to the factory. In consulting the factory, always have the unit model number and serial number at hand. This information is located on the identification label and is essential in retrieving your unit's performance and history record.

The RMA number issued to you should appear on the outside of the carton, if the unit is returned, or on any correspondence regarding your unit. When shipping a unit back to the factory, try to use the original packing container and shipping materials. The Service Department cannot take responsibility for any unit damaged in return shipment. All units must be returned prepaid to:

Clary Corporation
GT Service Center
150 E. Huntington Dr.
Monrovia, CA 91016

CLARY CORPORATION
LIMITED WARRANTY
STANDARD DT/CT/GT 800 - 2400VA
DEPOT REPAIR

1. TIME AND SCOPE OF WARRANTY:

- 1.1 Clary Corporation, (hereafter referred to as Clary) hereby warrants part shipped under this agreement to be free from defective workmanship for a period as stated below, following the date of shipment /accidental damage, misuse or normal wear shall not be construed as a defect.

This warranty is applicable only to the initial retail purchaser and is not transferable.

- (a) Two (2) Year Parts and Labor
- (b) Two (2) Year Battery Pro-Rated*

*** BATTERY PRO-RATED CALCULATION: CREDIT TOWARD NEW BATTERIES = CURRENT BATTERY PRICE X MONTHS OF UNEXPIRED LIFE DIVIDED BY 24**

- 1.2 The date of shipment as used herein will be the date on the Bill of Lading. If no Bill of Lading is issued, the date of shipment shall be shown on seller's shipping document.
- 1.3 No provision of this warranty shall cover equipment which has been altered or modified from the original specifications to which same was manufactured or work performed by owner or third party service company unless authorized in writing.
- 1.4 No provision of this warranty shall cover batteries over and beyond as described in Paragraph 1.1 above.

2. LIMITS OF "IN-WARRANTY" SERVICE LIABILITY

- 1.5 Clary is obligated during the in-warranty period to provide service and/or adjustments to the properly installed equipment for its intended use. Incorrectly installed and/or non-application use voids all stated warranties.
- 1.6 Equipment requiring in-warranty service must be returned to the factory, DEPOT REPAIR, Monrovia, California. Repair shall be returned with prior issued Return Material Authorization (RMA) by calling (800) 442-CLARY. All transportation charges prepaid, clearly tagged stating the nature of trouble experienced, and the disposition of the equipment after repair. The equipment will be returned collect by Clary to the location specified via the best least expensive carrier available or via customer's shipping instructions.
- 1.7 During the in-warranty period, no service charges should be payable by the buyer for service performed other than for service necessitated by accident, misuse, theft, abnormal line or source voltage fluctuations, abnormal conditions of operations, damage by the elements or damage resulting from adjustments, repairs, modifications made by other than Clary authorized personnel, or the buyer's failure to reasonable maintain the equipment.

TO THE EXTENT ALLOWED BY LAW, THE FORGOING WARRANTY IS EXCLUSIVE AND IS GIVEN AND ACCEPTED IN LIEU OF ANY AND ALL OTHER WARRANTIES, EXPRESSED OR IMPLIED, INCLUDING WITHOUT LIMITATION THE IMPLIED WARRANTIES OF MERCHANTABILITY AND FITNESS FOR A PARTICULAR PURPOSE, THE REMEDIES OF BUYER SHALL BE LIMITED TO THOSE PROVIDED HEREIN. IN NO EVENT WILL SELLER BE LIABLE FOR COLLATERAL OR CONSEQUENTIAL DAMAGES. TO THE EXTENT ALLOWED BY LAW, CLARY SHALL NOT BE LIABLE FOR LOSS OF PROFITS, INJURIES TO PROPERTY, LOSS OF USE OF PRODUCTS OR ANY ASSOCIATED EQUIPMENT. No person is authorized to assume in behalf of Clary any obligation or liability in connection with the sale warranty or service policy of any products manufactured and/or marketed by Clary Scientific beyond the warranty description on the face hereof.

3. PRODUCT CHANGES

- 1.8 Clary reserves the right to make changes, additions, and/or improvements in its products without incurring any obligation to install them on its products previously sold.