

Owner's Operating Manual

CMN SERIES CONTINUOUS POWER SYSTEM

MODEL COVERED:

CMN3000R

CMN4000R

CLARY CORPORATION

150 E. Huntington Dr.

Monrovia, California 91016

Telephone  626-359-4486

 800-44 CLARY

Fax.  626-305-0254

World Wide Web  [HTTP: // WWW.CLARY.COM](http://WWW.CLARY.COM)

E-Mail  [SALES @ CLARY.COM](mailto:SALES@CLARY.COM)

Information contained herein is the property of Clary Corporation, is proprietary, confidential, and not to be disclosed, disseminated or used except for the purpose provided by

CLARY CORPORATION

TABLE OF CONTENTS

TITLE	PAGE
TABLE OF CONTENTS.....	2
INTRODUCTION.....	3
TECHNICAL DESCRIPTION.....	4
PACKAGING.....	6
PHYSICAL DESCRIPTION.....	7
INSTALLATION AND OPTIONS.....	10
OPERATION.....	10
SIGNALS AND INTERFACING.....	12
SPECIFICATIONS.....	13
CARE AND MAINTENANCE.....	13
SERVICE AND REPAIR.....	15

INTRODUCTION

Congratulations! You have selected the highest quality protection for your *continuous power* needs. This unit offers a quiet and compact package with superior performance you can depend on. You now own a **CMN SERIES Continuous Power System (CPS)** which is an all *Digital Technology (DT)* product manufactured by Clary Corporation, the first name in uninterruptible power system (UPS) reliability. The *Continuous Power System* is the highest order in the hierarchy of UPS products. When power problems occur, there can be no compromising the reliability of your power solution. The **CMN SERIES Continuous Power System** is your complete power solution.

This Owners's Operating Manual is provided with your new **CMN SERIES** unit. It will enhance your understanding of the product and its functions. **Read this handbook carefully in the order it is presented prior to operating your unit.** This will save you time and effort in your installation and application. The illustrations provided will familiarize you with this product's operating modes and components. Always operate the unit within the guidelines and specifications provided to maximize safety and the lifetime of the unit. Also, your understanding of the product is a key element in getting the most out of your **CMN SERIES**.

IMPORTANT SAFETY INSTRUCTIONS, SAVE THESE INSTRUCTIONS

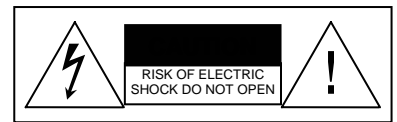
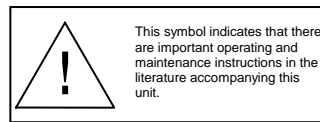
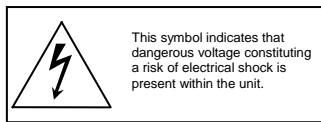

This manual contains important safety instructions that should be followed during installation and maintenance of the UPS and batteries. Be aware of the following symbols and their meaning as they appear throughout the manual:

This equipment generates and uses radio frequency energy and if not installed and used properly in strict accordance with the manufacturer's instructions, may cause interference to radio and television reception. All units in this manual have been tested and found to comply with the limits for a Class A computing device in accordance with the specifications in Subpart J of Part 15 of FCC Rules, which are designed to provide reasonable protection against such interference in a commercial installation. However, there is no guarantee that interference will not occur in a particular installation. If this equipment does cause interference to radio and television reception, which can be determined by turning the equipment off and on, the user is encouraged to try to correct the interference by one or more of the following measures:

- ☐ Reorient the receiving antenna.
 - ☐ Relocate the UPS with respect to the receiver.
 - ☐ Move the UPS away from the receiver.
 - ☐ Plug the UPS into a different outlet so that the UPS and receiver are on different branch circuits.
- If necessary, the user should consult the dealer or an experienced radio/television technician for additional suggestions. The user may find the following booklet prepared by the Federal Communications Commission helpful:
"How To Identify and Resolve Radio-TV Interference Problems"
This booklet is available from the U.S. Government Printing Office, Washington, DC 20402, Stock No. 004000003454.

TECHNICAL DESCRIPTION

The Digital Technology-High Temperature CMN Series *Continuous Power System (CPS)* is a revolutionary new concept in total power protection and management. The CMN SERIES is a microprocessor-based UPS that now allows the user to set most of the control feature parameters. By directly linking a personal computer to the RS232 port, frequency settings and operation, alarm signals, load switching, etc. can all be programmed to meet specific application requirements.

The CMN SERIES is a true on-line, continuous power UPS. In the tradition of Clary products, the CMN SERIES generates the same high quality and proven reliability to provide the best power protection available for today's critical applications. In keeping with state-of-the-art design, the power electronics are completely governed by an on-board microprocessor. Given the powerful memory capability of today's micro controllers, this microprocessor has evolved the UPS into an all-in-one complete power distribution and monitoring center. Not only is your critical load insured of the most reliable and constant power available, but the user may now continuously track status of the supply components that keep the entire system operational. Production downtime can now be virtually eliminated by knowing exactly what patterns the supply utility power maintains and by knowing exactly the condition and life expectancy of the battery reserve.

Reference the block diagram for a simplified explanation of the system's operation. The AC utility source is connected to the power and micro electronics when the input switch is closed. The input line is filtered, power factor corrected and rectified for enhanced performance without disturbing other equipment that may share the same utility circuit.

The microprocessor controls an *Inverter Generator* that produces a low harmonic, AC sinewave for continuous power applications.

When the input AC utility line fails, the battery circuit within this system takes over to ensure continuous power. Only until properly rated power is returned, does the microprocessor reconnect the input source back into the system.

The microprocessor is directly tied to an external RS232 connector port. This allows the user to monitor and even set some of the operating parameters. With a simple link to a personal computer using the UPS software program, you can actually view, on your monitor, the event history of the power distribution system with the CMN SERIES unit as the central hub. More sophisticated users may implement the optional SNMP package to accomplish full *Network Power Management*.

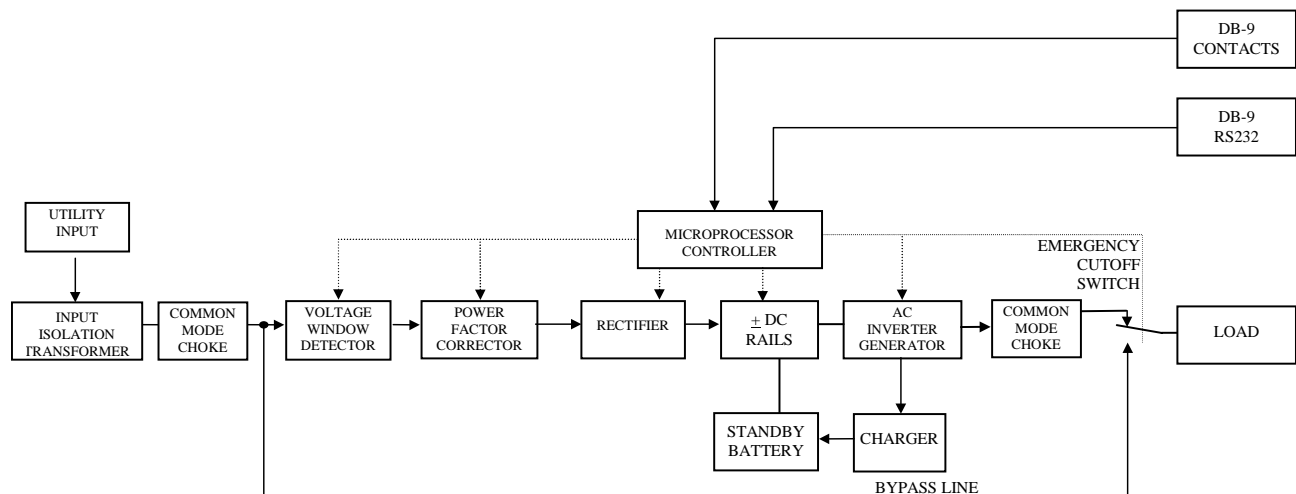

**CMN SERIES
REAR PANEL**

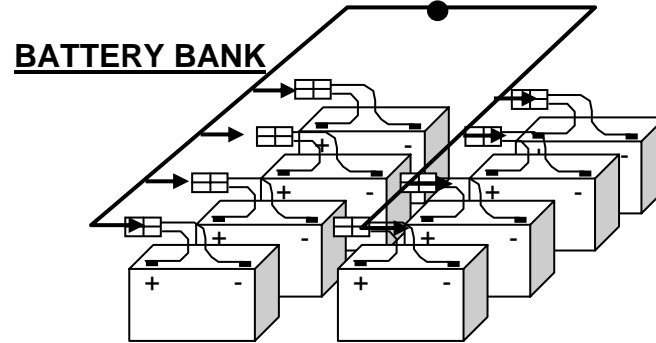
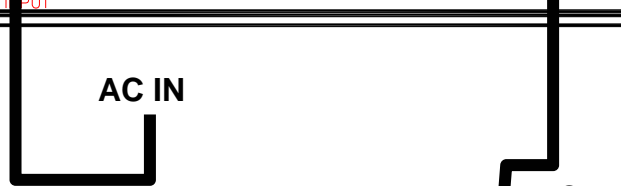
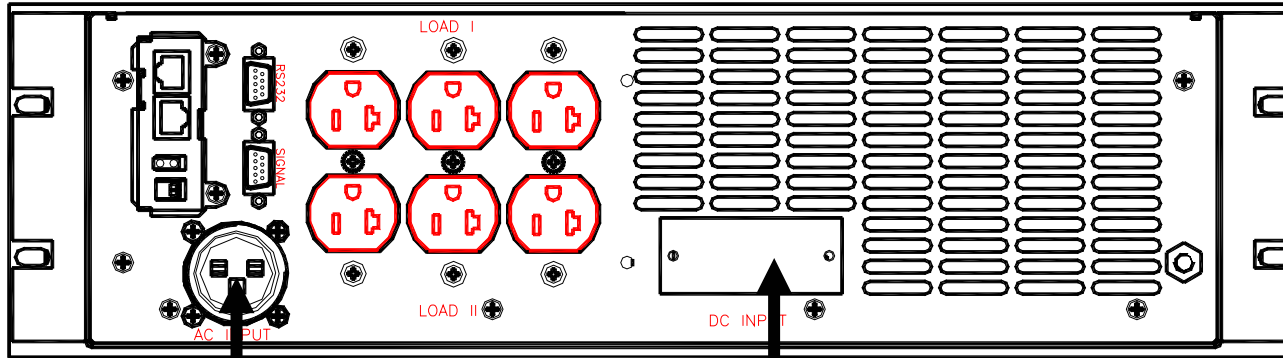

SIMPLIFIED SYSTEM INTERCONNECT

PACKAGING

Your CMN SERIES has been carefully packaged to withstand most abuse sustained during shipment. The packing material has been specifically designed to protect this system for normal handling, using most shipping carriers. If there is significant damage to the carton, or if there is any physical damage to this unit, report this to your carrier.

These units are encapsulated in a protective wrap that comes apart once the product is removed from



the shipping carton. Save all packing material for future use.

Take extra precaution when removing or returning it to the box. Because this unit contains a battery, it can be quite heavy. Never attempt to unpackage the equipment unassisted.

The packaging also contains important information on use and care as well as valuable warranty information. Read all materials before storing this literature with your other valuable product documents.

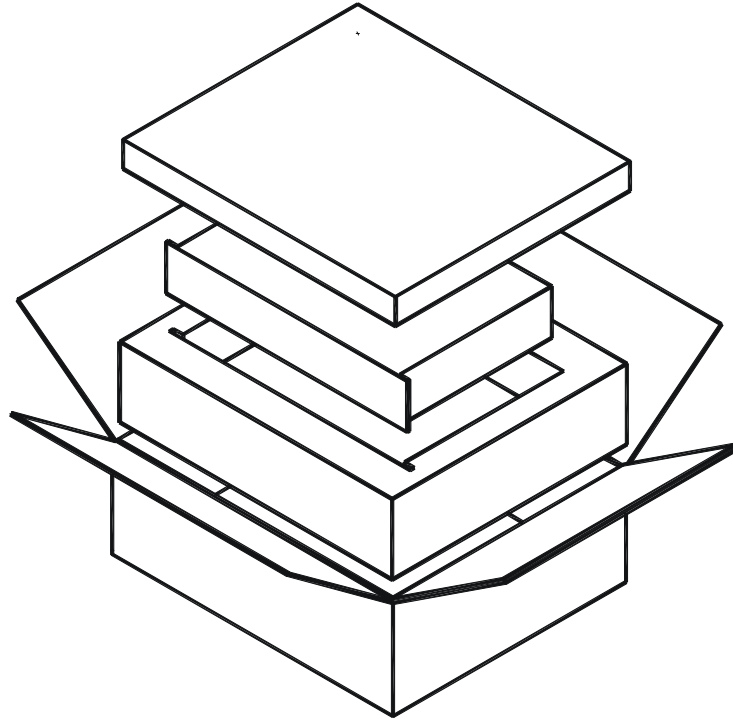

PHYSICAL DESCRIPTION

This section will point out and illustrate the various indicators, functions and controls of the CMN SERIES UPS. Pictured is the front view of the system, then followed by the rear view. The important attributes of the CMN SERIES unit is numbered to assist you in locating them on your machine and also to fully explain its function and how it relates to system operation.

Numbers on the drawing will correspond to the operating component's name at the bottom with a brief identification. In the next section, a complete explanation of all numbered items will be enhanced to ensure you have a full understanding of the operation of this system.

Visual indicators used on the front panel are long lasting, very efficient, light emitting diodes (LED). When operating the push-button switches, always hold the switch in for at least two seconds to insure function confirmation. This feature has been implemented into the system design to avoid inadvertent operation of any of the user-available functions.

The rear panel has been engineered with the user's multiple applications in mind. Two load outputs are provided with three receptacles per output. The outputs can be independently switched on or off.

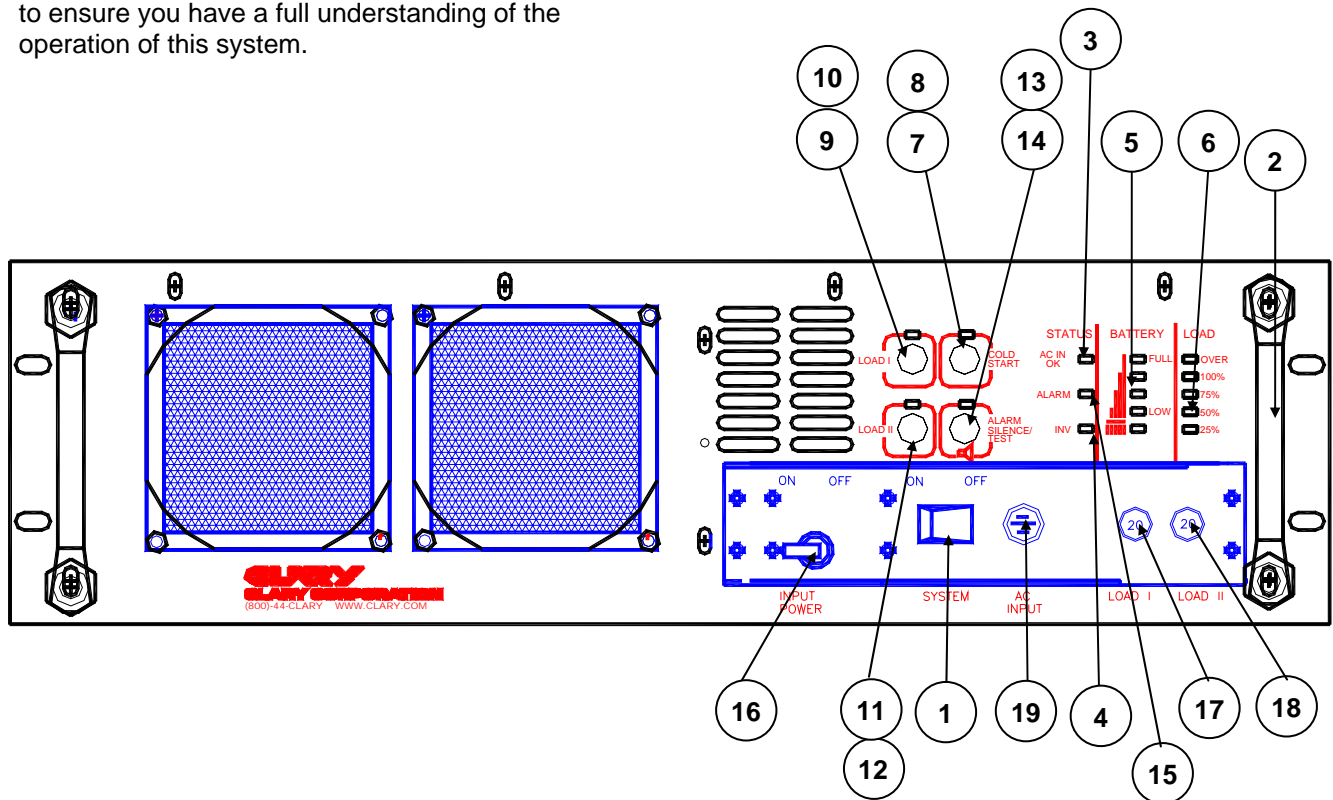

RACKMOUNT FRONT PANEL VIEW

- | | |
|--|--|
| <ul style="list-style-type: none"> 1 SYSTEM POWER SWITCH 2 HANDLES 3 AC In Ok- Input line indicator 4 INVERTER - Inverter operating indicator 5 BATTERY – Battery level indicators 6 LOAD – Load level indicators 7 COLD START - DC start switch 8 COLD START ACKNOWLEDGE INDICATOR 9 LOAD I - Enable switch for top row of output receptacles 10 LOAD I ACKNOWLEDGE INDICATOR | <ul style="list-style-type: none"> 11 LOAD II - Enable switch for bottom row of output receptacles 12 LOAD II ACKNOWLEDGE INDICATOR 13 ALARM SILENT/TEST - Dual function switch 14 ALARM SILENT/TEST ACKNOWLEDGE INDICATOR 15 ALARM - Fault indicator 16 INPUT CIRCUIT BREAKER 17 20A CIRCUIT BREAKER FOR LOAD I 18 20A CIRCUIT BREAKER FOR LOAD II 19 AC INPUT INDICATOR |
|--|--|

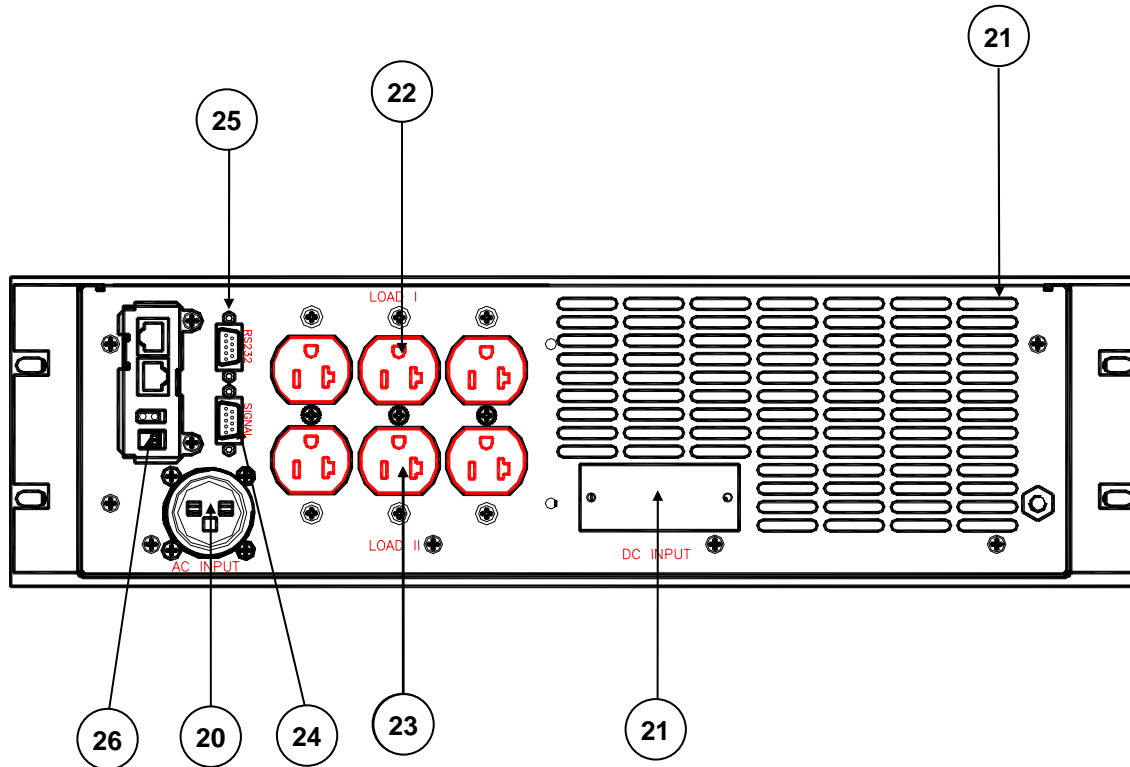

RACKMOUNT REAR PANEL VIEW

- | | | | |
|-----------|---|-----------|---|
| 20 | INPUT - AC Line Plug | 24 | SIGNAL – Open Collector |
| 21 | DC INPUT - Auxiliary battery connector | 25 | RS232 - RS232 communications signals |
| 22 | 120VAC OUTPUT (LOAD 1) - System output | 26 | SNMP - Optional |
| 23 | 120VAC OUTPUT (LOAD 2) - System output | | |

SUMMARY OF INDICATORS AND CONTROLS

SYSTEM POWER SWITCH - The main control switch that engages utility power to the entire unit. By activating this switch it initializes normal operation. Input circuit breaker must be on.

AC In - The utility input indicator that identifies status of the line voltage. If the line voltage is within the specified range, it will remain lit. If the AC input is out of range, this indicator will flash in 1 to 2 second intervals.

Inverter - This indicator identifies the status of the regenerated, conditioned protected output power. This indicator will stay ON as long as protected power is available from the power inverter generator.

Battery Level - This is the battery status bar graph. During normal operation, this bar graph will show the charging of the battery; all indicators lit will represent a fully charged battery. During battery operation, this bar graph represents a discharge meter indicating less battery time available as each L.E.D. turns OFF.

Load Level - This is the system output capacity status bar. The number of L.E.D.s on the graph indicate an approximate percentage of system full load. All lights being ON would indicate full load.

Cold Start - A momentary push-button switch to activate the system in the event no utility power is present. The system will be allowed to start up by using power from its batteries. Turn on the System Power Switch. Press and hold the Cold Start Switch until the audible alarm beeps once. Press and hold the LOAD I or II switch. The system will maintain a load depending upon the condition of the battery.

Load I and Load II - A momentary push-button switch that toggles the output LOAD I or II AC output outlets at the rear panel "ON /OFF". The indicator above the switch will be ON to represent that LOAD I OR II Is activated. The output can be turned OFF by pressing and holding the switch. While the switch is depressed, the indicator will blink to represent transition. Once the indicator stops blinking, the switch can be released for a successful transition.

Alarm Silent/Test - A momentary push-button switch that controls two different functions depending on the mode of operation. In the normal mode of operation, if this switch is depressed and held in, the above indicator will blink. Once it stops blinking, the unit will perform an internal 1 to 2 minute battery check. Once the test is completed, if the battery is below standards, the system will indicate that the battery needs replacing. The system will not run this battery test unless the battery is detected to be fully charged. During battery or abnormal operation, an audible alarm will accompany this mode. By depressing this switch, the adjacent indicator will blink. When it stops blinking, the alarm will be silenced. Once the fault or reason for the alarm is corrected, this audible alarm condition will automatically reset. The audible alarm can be re-enabled during abnormal conditions by pressing and holding the switch again.

NOTE - All switches must be held in for at least two seconds to engage their function. This is to prevent any inadvertent switch operation.

Alarm - This is a fault indicator that will light in the event that the inverter generator is non-operable. This could be due to an "over-temperature" situation or an inverter malfunction.

DC INPUT - The battery input connector to add batteries.

120VAC OUTPUT (Load I & Load II) - The output groupings that can be independently controlled by the corresponding front panel switch. During normal operation, inverter generator power is supplied at these outlets.

SIGNAL - A DB-9 subminiature, female connector that outputs the open collector signal contacts for utility *interrupt*, *low battery* and *inverter active* conditions.

RS232 - A DB-9 subminiature, female connector that outputs true RS232 communications signals.

COOLING FAN - The cooling device necessary to maintain operation without defect. This cooling fan draws air directly across the internal heatsink.

IDENTIFICATION LABEL - The model number and serial number of the system is located here. Always refer to this information when corresponding with the factory.

INSTALLATION

The **CMN Series** unit is designed for installation in a protected environment. Units may be installed in a 19" rack system. The system is lightweight and can be easily moved. Some important points to consider when positioning a unit for operation:

- * A properly rated (preferably dedicated) outlet is accessible for the power cord supplied with the unit. It is not recommended to modify the supplied cord in any way nor should an extension cord of any kind be used.
- * The cord paths in the system installation should remain clear of foot traffic or anything else that may disturb permanent connection.
- * The installation site should maintain an ambient air temperature of less than 40°C. When the environment for the system remains cooler during operation, there is less stress on the batteries and the internal electronics.
- * The air inlets, vents and fan should not be obstructed or blocked in any way.

- * The air should remain free from excessive dust and chemical fumes.
- * The front panel is designed to fit in a standard 19" rack. This panel fills a 5 ¼" slot. Guide Rails or slides are recommended to support the unit's mainframe. This system weighs in excess of 85 pounds; front panel mounting is not intended to support the entire unit. The system has pre-tapped aluminum slide bars available to accept some standard slide configurations. Contact the factory for optional slide kits and accessories if assistance is required in properly mounting in a rack.

Once a location has been selected and the external battery pack is connected, it is ready for operation. Allow at least 48 hours, after the system is first installed, to fully charge the external battery to a maximum state. Charge time depends on the size of batteries used.

OPTIONS

This rackmountable UPS is supplied with a matching rackmountable auxiliary battery box. This battery box is designed to host one or two strings of batteries, to extend battery support times. The additional time is dependent on the unit capacity and load size.

The battery pack is rated at 96VDC and comes with a mating cable that directly connects to the battery port at the rear of the UPS. This connector is exposed, after removing the attached cover plate. The connector on the battery and UPS are the same so that the cable can be plugged in either way. The connector used is a locking type, when fully engaged, will not allow the cable to be pulled apart, unless the locking ears are depressed.

The battery box fits a 3 1/2" slot into a 19" rack, just like the UPS. The full depth of the battery, however, is only 23". It is slide ready and weighs approximately 48 pounds in a single battery configuration. It weighs 85 pounds in a dual battery configuration. An additional port is available at the rear of the battery box to add continuous battery strings if necessary.

The battery box is designed to be upgradeable. If the single string is not adequate, the user may order an additional string of batteries that can be easily installed in the existing box. By removing the existing mounting screws on the existing battery, it can slide over and the additional set can now be secured, with four additional screws, adjacent to the original set. The internal harness has an open connector provided for the second set. After plugging this connector together, the upgrade is complete.

Once the system has been properly installed, it is ready to operate. The following procedures will explain how to start-up the system while plugged into rated electrical power and also how to start-up with no AC power available.

Normal Operation on AC Start-Up:

- Verify that the unit is plugged into properly rated electrical power.
- Connect Cable from Aux. Battery Box to UPS.
- Position the Input Circuit Breaker to the ON position.
- Position the System Power Switch to the ON position and the BYPASS SWITCH to the INV position. You will now have Bypass power at the receptacles.

The system will proceed through about a three second diagnostic where all the L.E.D.s will sequence ON then OFF. The AC IN L.E.D. will flash several times and the audible alarm will give a short burst. The AC IN light L.E.D. will then stay ON and the battery level meter will light to at least an 80% level. The INVERTER L.E.D. will come ON and inverter power will now be available at all the output receptacles. The LOAD I and LOAD II will come ON. Actual load may be connected at any time during this procedure, however inverter power is only available when the L.E.D. above either of the LOAD switches is ON continuously.

Battery Operation after AC Start-Up:

- Unplug the unit from the standard wall outlet. The AC In L.E.D. will flash at two to three second intervals. Within 5 seconds, the audible alarm will sound at half-second intervals.
- Push and hold in the ALARM SILENT/TEST switch until the audible alarm is inhibited.

If operation were to continue in this mode, the BATTERY LEVEL meter would start to turn OFF, one L.E.D. at a time starting from the top. Once the last L.E.D. is left, the alarm will sound in a constant tone. Had the alarm been previously silenced, it would still re-enable to alert the user of limited operation. This alarm can also be silenced as before. If the unit is allowed to operate further, it will time shut off the loads. If power were to return, the unit will automatically restart and return to the condition it was in at the moment it went into *Battery Mode*.

DC Start Operation (Cold Start)

If no utility power is available at the time backup power is required, the unit may be started to accomplish abbreviated tasks. The limitations of the battery prevent extended operations at full load.

- Position the System Power Switch to the ON position.
- Push and hold in the COLD START switch until the audible alarm beeps.

The unit will start up similarly to normal AC start-up except the AC IN L.E.D. will continue to flash. The LOAD outputs will come up in the OFF mode when using the COLD START feature. You must press and hold the LOAD I or LOAD II switch to activate the inverter.

Loading the System

The system can be loaded up to full rated load. As load is applied, the LOAD METER will start to turn ON. The LOAD METER will not work when you are in a "Manual Bypass". Once full load is achieved, the full LOAD METER should be lit. As additional load is applied, the top red OVERLOAD L.E.D. will come ON. If too much overload is applied, the audible alarm will sound. If this increased load is not removed within five seconds, the unit will discontinue output operation and latch into an alarm condition. The audible alarm will continue to sound and the ALARM L.E.D. will light. Reducing the load and cycling the System Power Switch OFF then ON can reset the system.

Programming the Outputs:

The outputs on startup can be programmed ON or OFF. The default mode is programmed to turn both load circuits ON whenever you power up the UPS on AC startup. They will stay energized until you turn OFF the UPS, the batteries run down during a power outage or if the appropriate load button is pressed. To program both loads to be OFF when the UPS is turned ON:

- Turn the UPS OFF.
- Turn the UPS ON while pressing and holding the LOAD I OR II switch.
- The UPS will come ON with both loads OFF and will remember this setting each time the unit is turned ON.

To program both loads to come ON:

- Turn the UPS OFF.
- Turn the UPS ON while pressing and holding both LOAD I and LOAD II switches (this definitely requires both hands). The UPS will remember this combination the next time it is powered ON.

To program LOAD I or LOAD II to come ON individually at startup:

- Turn the UPS OFF.
- Turn the UPS ON while pressing and holding either LOAD I or LOAD II switches.

SIGNALS AND INTERFACING

At the rear of the unit are two DB-9, subminiature, female connectors. These are provided for communications links to a computer or sophisticated monitoring device.

SIGNAL PORT DB-9 provides open collector type closures that typically signal *Utility Interrupt*, *Low Battery* and *Inverter Active* conditions. A system shutdown feature is also available on this port. Applying a +5-12V signal across the appropriate pins will cause the system to shutdown in battery mode.

SIGNAL PORT-(DB9) OPEN COLLECTOR

- 2- UTILITY INTERRUPTED SIGNAL
- 3- INVERTER ACTIVE SIGNAL
- 4- COMMON SIGNAL RETURN
- 5- LOW BATTERY SIGNAL
- 6- + UPS SHUTDOWN
- 7- - UPS SHUTDOWN

RS232 CONNECTOR

- 2- TRANSMITTING DATA (TX)
- 3- RECEIVING DATA (RX))
- 5- GROUND
- 6- DATA SET READY (DSR)
- 8- REQUEST TO SEND (RTS)

This conserves the battery life once an orderly shutdown has been accomplished. The system may be configured to shutdown by simply shorting pins 6 and 7. Contact the factory for configuration details. RS232 DB-9 is a true RS232 communications signal port. On rackmount units, this port is on a removable plate, which can be substituted with an optional SNMP card. Below is the pin out of the two connectors with their default assignments:

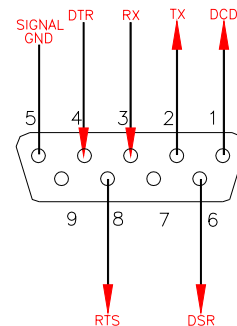
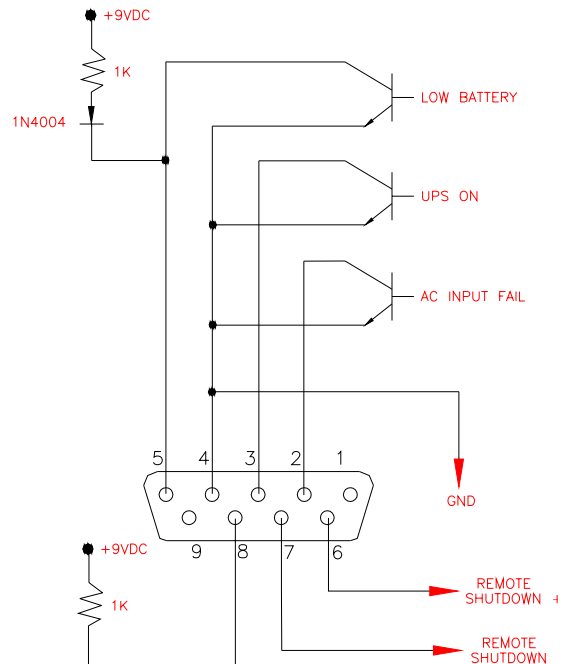

SPECIFICATIONS

ELECTRICAL	
Input	CMN3000R/CMN4000R
Voltage	120V +10%, -20% (without Battery discharge)
Power Factor Corrected	I/AW MIL STD. 1399 Sec. 300
Frequency	45 to 65Hz
Current(Amps) @ 120VAC	21A/28A @ 100% Non-Linear
Output	
Voltage	120VAC ± 3%
Frequency	50Hz / 60Hz (software select) Line Sync (software select)
Current(Amps)	25A/33A @ 100% Non-Linear
Crest Factor Ratio (Non-linear load and less than 5% THD) Typical	@50% Load Up to 4.8:1 @75% Load Up to 3.2:1 @100% Load Up to 2.4:1
Total Harmonic Distortion (THD)	3% Typ; 5% Max. (@100% Non-linear load)
Dynamic Response	±4% for 100% Step Load Change, 0.5 Millisecond Recovery Time
Overload	110% for 10 Minutes; 200% for 50 Milliseconds
Efficiency (UPS)	85-87% Typical
UPS Protection	Input and Output Short Circuit; Input and Output Overload; Excessive Battery Discharge
ENVIRONMENTAL	
Operating Temperature	0°C to 40°C
Humidity	0% to 95% Non-condensing
Altitude	Sea Level to 10,000 Feet
Audible Noise	42 dBA at Five Feet
MECHANICAL	
Input	CPC Type 3 Position Inlet Connectors
Output (Qty.)	Load 1 and Load 2 (3 each) NEMA Type 5-20R
Cooling	Low Velocity, Temperature Controlled Reversible Forced Air
Dimensions: HxWxD In.	5.25 x 19 x 23
Weight: Lbs. (Kg)	85 (38.8)

DESIGN	
Standard Features	Power Factor Corrected, Digital Regenerative™ On-Line, Sinewave Inverter Powers Load Continuously Extended Brownout Protection Designed for Non-linear Loads Continuous Operation on -25%,+12% Line Automatic Bypass RS232 Data Interface Software Selectable Output Frequency AC Output Switch Auxiliary Battery Connector Rear Mounted Ground Stud Optional SNMP Interface
Specifications	UL 1778, CUL, FCC Class A, IEEE 587/ANSI C62.41, IEC 555 @ 120VAC
MTBF	In Excess of 100,000 Hours
CONTROLS AND INDICATORS	
Visual Indicators Sequenced LEDs Single LED	Battery Level, Load Level AC Input, Inverter On, Load On Summary Alarm, Alarm Silence, Cold Start,
Front Panel Controls	Power On, Cold Start Alarm Silence, Battery Test AC Output On/Off, Bypass
Audible Alarms	Utility Interrupt, Inverter Failure Overload, Low Battery
RS232 Data Interface (DB-9F)	Full Interactive, Remote Computer Monitoring and Control of UPS Functions. Compatible with Systems Enhancement™ UPS Monitor & Control Software
Open Collector (DB-9F)	Allows Alarm Function Monitoring
Optional SNMP Interface (RJ45 or BNC)	Allows Full Control and Monitoring Over Network Connection.

Specifications subject to change without notice

CARE AND MAINTENANCE

This device is designed to be maintenance-free. It can be cleaned with a damp cloth or nonabrasive cleanser.

WARNING: Do not use ACETONE-BASE cleaning solutions. Keep cleaning solutions out of the electrical receptacles on this device.

Be sure filters, vents and fans are kept free from accumulation of dust, dirt or lint. Below is a simple maintenance schedule that will assist you in keeping the system at its peak level of performance and also minimizing potential premature failures.

Your system contains sealed maintenance-free batteries. When situated in the proper environment, with the proper charging and limited cycling, these batteries can last many years.

WARNING: Never attempt to service batteries. High voltage exists within the unit which could cause electrical shock. Servicing of batteries should be performed or supervised by personnel knowledgeable of batteries and the required precautions. Keep unauthorized personnel away from batteries. When replacing batteries, use the same number and type batteries.

CAUTION - Do not dispose of battery or batteries in a fire. The battery may explode.

CAUTION - Do not open or mutilate the battery or batteries. Released electrolyte is harmful to the skin and eyes. It may be toxic.

CAUTION - A battery can present a risk of electrical shock and high short circuit current. The following precautions should be observed when working on batteries.

1. Remove watches, rings, or other metal objects.
2. Use tools with insulated handles.
3. Wear rubber gloves and boots.
4. Do not lay tools or metal parts on top of batteries.
5. Disconnect the charging source prior to connecting or disconnecting battery terminals.
6. Determine if the battery is inadvertently grounded. If inadvertently grounded, remove source of ground. Contact with any part of a grounded battery can result in electrical shock. The likelihood of such shock will be reduced if such grounds are removed during installation and maintenance.

The internal rechargeable battery is recyclable. At the end of its useful life, under various state and local laws, it may be illegal to dispose of this battery into the municipal waste stream. Check with the factory for details in your area for recycling options or proper disposal.

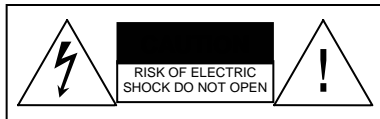

RECOMMENDED PREVENTATIVE MAINTENANCE SCHEDULE			
TIME	TASK	TOOLS REQ'D	INITIALS <input checked="" type="checkbox"/>
Every 6 mo.	Test battery operation, check back-up time	None	
Every 12 mo.	Thoroughly clean unit	Vacuum, brush	
Every 42 mo.	Replace battery	3/8 Hex Nut Driver	
Every 72 mo.	Replace cooling fans	Screwdriver	

SERVICE AND REPAIR

Your **CMN SERIES** is backed by one of the finest customer service teams available. Write or call them at any time to obtain more information about your unit.

Clary Corporation
150 E. Huntington Dr.
Monrovia, CA 91016
1-800-551-6111

If a problem should occur, it is important that you obtain a Return Material Authorization (RMA) number from the Service Department to process any unit returned to the factory. In consulting the factory, always have the unit model number and serial number at hand. This information is located on the identification label and is essential in retrieving your unit's performance and history record.

The RMA number issued to you should appear on the outside of the carton, if the unit is returned, or on any correspondence regarding your unit. When shipping a unit back to the factory, try to use the original packing container and shipping materials. The Service Department cannot take responsibility for any unit damaged in return shipment. All units must be returned prepaid to:

Clary Corporation
SERVICE DEPT.
150 E. Huntington Dr.
Monrovia, CA 91016

**CLARY CORPORATION
LIMITED WARRANTY
STANDARD CMN SERIES
DEPOT REPAIR**

Clary Corporation warrants the electronics of the Clary CMN Series UPS to be free from defects in material and workmanship for a period of two years from the Date of Purchase. If, in Clary's opinion, the electronics fail to meet its published specification due to a defect in material and workmanship covered by this warranty, Clary Corporation will repair or replace the warranted Unit at no cost to the customer for parts and labor.

This warranty is applicable only to the initial purchaser and is not transferable. The LIMITED WARRANTY is:

- (a) Two (2) year Parts and Labor (Electronics)
- (b) Two (2) year Battery pro-rated*

*Battery Pro-Ration Calculation: Credit toward new batteries= Current battery list price x Months of unexpired life ÷ 24.

Equipment supplied by Clary Corporation, but not manufactured by Clary Corporation, is warranted solely by the manufacturer of such equipment. Clary Corporation does not warrant equipment not manufactured by Clary Corporation.

This warranty does not apply to any unit that has been subject to neglect, accident, abuse, misuse, misapplication, incorrect connection/installation, or that has been subject to repair or alteration not authorized in writing by Clary Corporation. Incorrectly installed and/or non-application use voids all stated warranties. THIS WARRANTY IS THE PURCHASER'S (USER'S) SOLE REMEDY AND IS EXPRESSLY IN LIEU OF ANY OTHER WARRANTY, AND THERE ARE NO OTHER EXPRESSED OR IMPLIED GUARANTEES OR WARRANTIES (INCLUDING ANY IMPLIED WARRANTY OF MERCHANT ABILITY OR FITNESS FOR PURPOSE). In no case will Clary Corporation's liability under this contract exceed the value of the Unit furnished.

In no event shall Clary Corporation be liable for indirect, incidental, special or consequential damages. Clary Corporation shall not be responsible for failure to provide service or parts due to causes beyond Clary Corporation's reasonable control.

Any advice furnished the Purchaser (User) before or after delivery in regards to use or application of Clary Corporation equipment is furnished without charge and on the basis that it represents Clary Corporation's best judgement under the circumstances. The use of any such device by the Purchaser (User) is sole and entirely at his or her own risk.

This limited warranty applies only to equipment installed in the fifty United States and Canada.

Clary Corporation reserves the right to make changes, additions, and/or improvements in its products without any obligation to install them on its products previously sold.

Equipment requiring in-warranty service must be returned to the factory, DEPOT REPAIR, Monrovia, California. A Returned Merchandis Authorization Number (RMA#) must be obtained by calling (800) 551-6111 prior to returning any equipment to Clary Corpoation . Inbound transportation charges are customer's responsibility. Equipment should be tagged stating the nature of the trouble experienced. The RMA# must be clearly visible on shipping container, shipping label or packing slip. It is recommended to return equipment to Clary Corporation in the original shipping container. The equipment will be returned collect to the location specified via the best least expensive carrier available or via customer's shipping instructions