

OWNER'S OPERATING & MAINTENANCE MANUAL

CONTINUOUS POWER SYSTEM

DIGITAL TECHNOLOGY CMN SERIES
2400VA

Model: CMN2400D-PD

CLARY CORPORATION

150 E. Huntington Dr.
Monrovia, California 91016

Tel. 626-359-4486
800-44-CLARY

[HTTP://WWW.CLARY.COM](http://www.clary.com) Fax. 626-305-0254
E-MAIL SALES@CLARY.COM

Information contained herein is the property of Clary Corporation, is proprietary, confidential, and not to be disclosed, disseminated or used except for the purpose provided by
CLARY CORPORATION

P/N 510-15176-NR

E.O.# 412359 10/9/07

TABLE OF CONTENTS

PART 1

TITLE	PAGE NO.
INTRODUCTION	3
THE CMN SERIES RACKMOUNT	4
UNPACKING THE UNIT	5
PHYSICAL DESCRIPTION.....	6
PINOUTS FOR CONNECTORS	8
SUMMARY OF INDICATORS AND CONTROLS	10
CONTROL PANEL.....	12
SUMMARY OF INDICATORS AND CONTROLS	13
SPECIFICATIONS	14
INSTALLATION	15
OPERATION	16
SIGNALS AND INTERFACING	19
CARE AND MAINTENANCE.....	20
BATTERY PACK INSTALLATION AND REMOVAL.....	21
SERVICE AND REPAIR	22
WARRANTY.....	23

LIST OF FIGURES

PART 1

TITLE	PAGE NO.
CMN SERIES BLOCK DIAGRAM	4
UNPACKING THE UNIT	5
RACKMOUNT FRONT VIEW	6
RACKMOUNT REAR VIEW	7
CONTROL PANEL FRONT VIEW.....	12
SIGNALS AND INTERFACING	19

INTRODUCTION

The following text is a complete product description, operating guide and basic maintenance summary of the CLARY **CMN Series** Rackmount, digital *continuous*, uninterruptible power system (UPS). This UPS provides a fully on-line sinewave, completely regenerated for typical non-linear loads.

The CMN2400D-PD has an output rating of 2400VA. The output power factor rating is 0.7, which means this unit can deliver up to 1680 watts.

This instruction manual is provided with this unit to enhance your understanding of the product and its applications. Read this handbook carefully in the order it is presented prior to operating or servicing to avoid harm or damage to you or the unit. The UPS may be referred to in the text as the **CMN Series**, Rackmount, etc. Certain references may be made to specific model numbers, however, the basic difference between models is the output power it can supply.

IMPORTANT SAFETY INSTRUCTIONS, SAVE THESE INSTRUCTIONS

This manual contains important safety instructions that should be followed during installation and maintenance of the UPS and batteries.

Always operate the unit within the guidelines and specifications presented to maximize this system's efficiency and lifetime.

THE CMN SERIES RACKMOUNT

A digital on-line, sinewave UPS is the only total solution to virtually any power problem. It effectively provides *CONTINUOUS POWER*, by regenerating the incoming AC to DC and then back to a highly regulated AC. A battery is provided at the input of the AC Inverter to support the load in case of utility interruption. The *CONTINUOUS* power concept is a step above the typical UPS, in that, power protection is maintained under any circumstance for the most complete and reliable service to the critical load. This *CONTINUOUS* power UPS is designed for the critical, *must-not-fail* applications.

The **CMN Series** rackmount is engineered with the latest Insulated Gate Bipolar Transistor/Pulse Width Modulation (IGBT/PWM) technology for high efficiency and reliability. The electronics are completely governed by an on-board microprocessor. This allows for not only a digitally processed precision output waveform, but also provides for full interactive access and control for the user through an RS232 computer port.

Refer to the simplified block diagram, Figure 1, for system description. An AC source is fed through a double pole breaker for both Hot and Neutral protection. This breaker then feeds the power circuits and all internal microelectronics. Input voltage is monitored to allow for continuous operation over a -25% to +35% range of nominal voltage for all load conditions. An input voltage variation outside the preset window will transfer operation to battery energy without a shutdown.

The input AC, when within the specified window, is power factor corrected and then sent to the rectification stage. The DC rectifier stage provides both positive and negative voltages to a DC rail stage, which then feeds the digitally controlled inverter AC. The AC inverter supplies the load and supports the battery charger as long as input utility is available. Normally the output inverter is at 60Hz independent of the input line frequency. The output inverter is synchronized to the utility line frequency.

During a utility power-loss, the AC rectification and battery charging capabilities of the UPS become inactive. The fully charged battery system now becomes the source of power feeding the AC Inverter generator. All systems are controlled by the digital microprocessor at all times.

The **CMN Series** on-line topology is unique to other on-line systems in that it is designed to meet the needs of all non-linear type loads while providing input power factor correction. Computers and telecommunications equipment, with their switching power supplies are considered a non-linear load, which can be very abusive to most power protection equipment and could decrease life expectancy. The **CMN Series** is specially designed with a power factor corrected input to eliminate harmonics back into the power source as well as accept non-linear loads and protect them efficiently without any output waveform degradation common to other UPS designs.

If the unit is overloaded, it will shutdown completely if the overload is not corrected within 3 seconds.

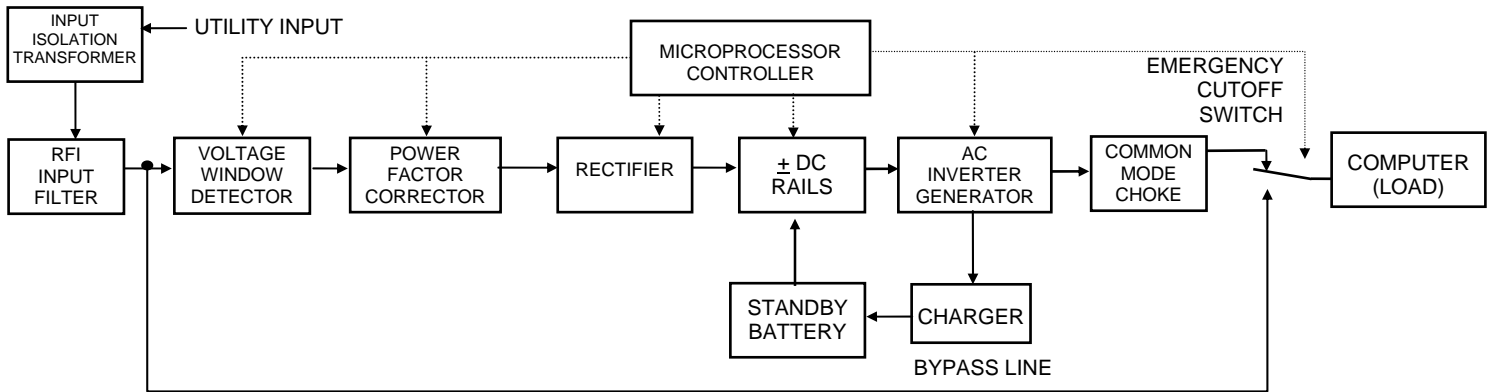

FIGURE 1: CMN SERIES BLOCK DIAGRAM

UNPACKING THE UNIT

Your UPS has been carefully packaged to withstand most abuse sustained during shipment. If there is significant damage to the carton, or if there is any physical damage to this unit, report this to your carrier.

It is recommended to save the shipping container and packaging materials for future transporting, if necessary. Transporting the unit in other than supplied shipping materials can result in unit damage not covered by the manufacturer's warranty.

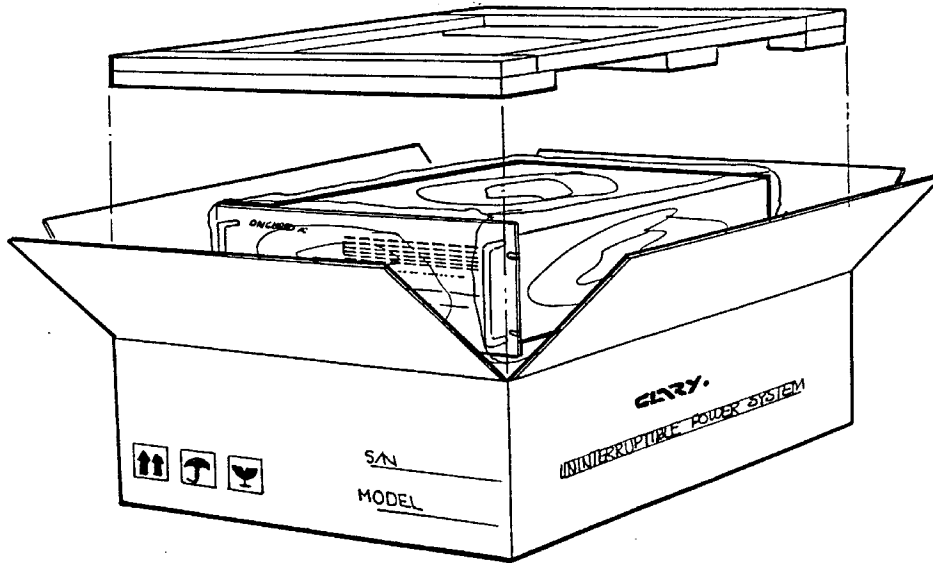
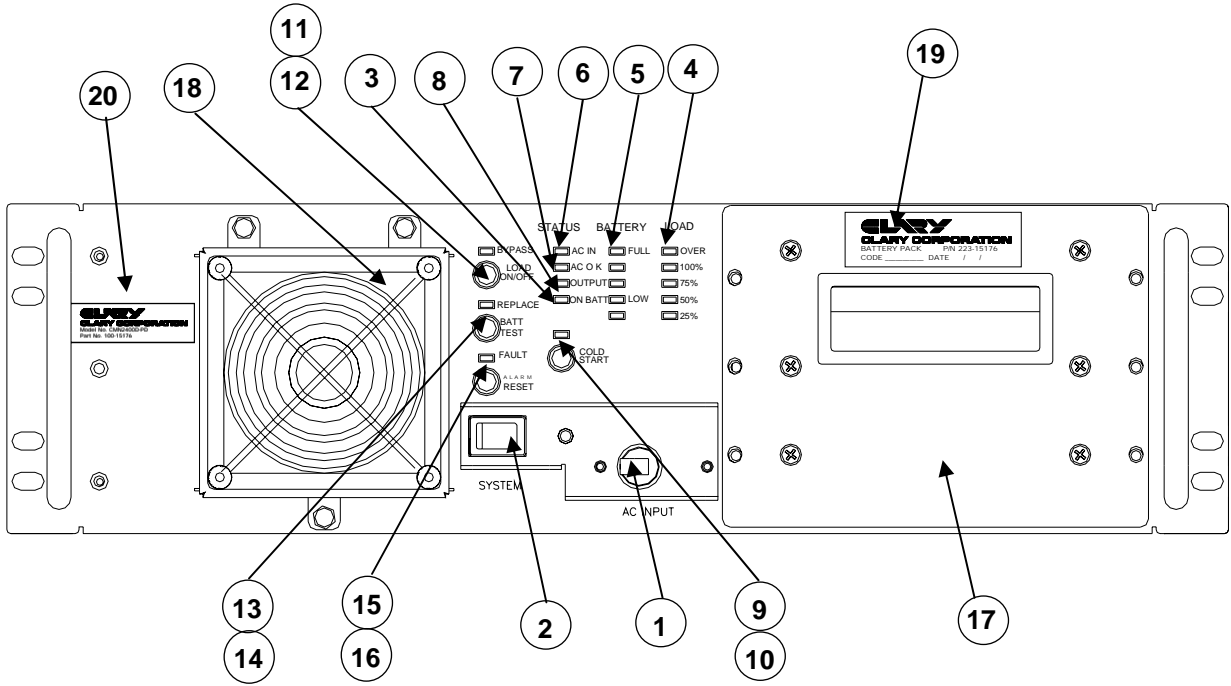

FIGURE 2: UNPACKING THE UNIT

PHYSICAL DESCRIPTION

The following illustrations depict the basic Rackmount **CMN Series** unit. Reference the SUMMARY OF INDICATORS AND CONTROLS Section for a further description of the call-outs.

FIGURE 3: RACKMOUNT FRONT VIEW



- | | | | |
|----|-----------------------|----|------------------------------|
| 1 | AC INPUT POWER SWITCH | 11 | LOAD ON/OFF SWITCH |
| 2 | SYSTEM ON/OFF SWITCH | 12 | BYPASS LED |
| 3 | ON BATTERY LED | 13 | BATTERY TEST SWITCH |
| 4 | LOAD LEDs | 14 | REPLACE BATTERY LED |
| 5 | BATTERY LEVEL LEDs | 15 | ALARM RESET SWITCH |
| 6 | AC IN LED | 16 | FAULT LED |
| 7 | AC OK LED | 17 | BATTERY PACK-SLIDE OUT |
| 8 | AC OUTPUT LED | 18 | FAN GUARD |
| 9 | COLD START SWITCH | 19 | BATTERY PACK DATE CODE LABEL |
| 10 | COLD START LED | 20 | UNIT IDENTIFICATION LABEL |

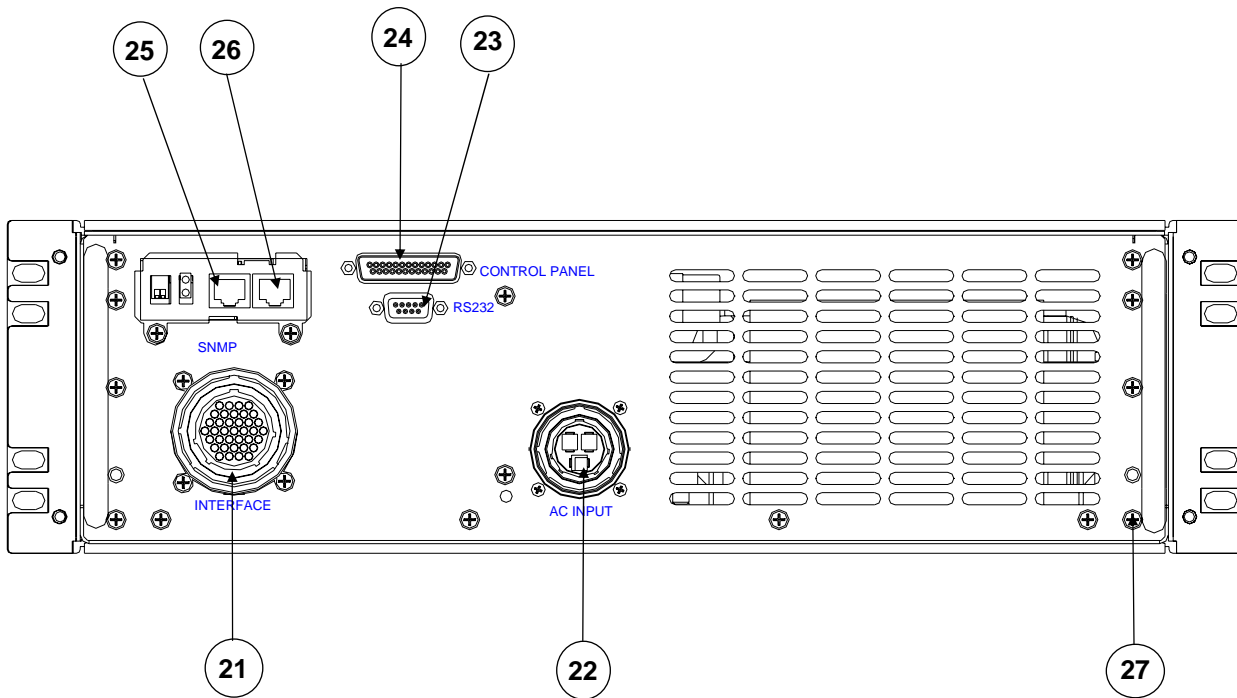

FIGURE 4: RACKMOUNT REAR VIEW

- | | | | |
|-----------|---|-----------|--------------------|
| 21 | INTERFACE- CPC Type 37 Pin Connector | 25 | SNMP COM |
| 22 | INPUT - CPC Type Connector | 26 | SNMP LAN |
| 23 | RS232 CONNECTOR – DB9F | 27 | GROUND STUD |
| 24 | CONTROL PANEL CONNECTOR – DB25F | | |

PINOOTS FOR CONNECTORS

Interface 37 Pin Connector

Pin 1 – Load 1	Pin 21 – +5V
Pin 2 – Load 1 Neutral	Pin 22 – Temp Fail 1, Hi Temp, Shutdown
Pin 3 – Load 2 Neutral	Pin 23 – Load 5
Pin 4 – Load 1 Ground	Pin 24 – Fan Neutral
Pin 5 – Load 2	Pin 25 – Load 5 Ground
Pin 6 – Load 3 Neutral	Pin 26 – Spare 2
Pin 7 – Load 4 Neutral	Pin 27 – Fan Fail 1, OR'd with Fan Fail 2
Pin 8 – Load 2 Ground	Pin 28 – Temp Fail 2, Warm, Alarm
Pin 9 – 5V Return	Pin 29 – Load 6
Pin 10 – Load 3	Pin 30 – Load 6 Ground
Pin 11 – Load 5 Neutral	Pin 31 – Load 7 Ground
Pin 12 – Load 6 Neutral	Pin 32 – Load 8 Ground
Pin 13 – Load 3 Ground	Pin 33 – Fan Fail 2
Pin 14 – 5V Return	Pin 34 – Load 7
Pin 15 – +5V	Pin 35 – Load 8
Pin 16 – Load 4	Pin 36 – Fan Hot
Pin 17 – Load 7 Neutral	Pin 37 – Fan Ground
Pin 18 – Load 8 Neutral	
Pin 19 – Load 4 Ground	
Pin 20 – Spare 1	

AC Input Connector

Pin 1 – 115VAC Line
Pin 2 – 115VAC Neutral
Pin 3 - GND

CONTROL PANEL CONNECTOR

Pin 1 – Remote on/
Pin 2 – AC Fail/
Pin 3 – UPS ON/
Pin 4 – Signal Gnd
Pin 5 – Low Batt/
Pin 6 – Shutdown +
Pin 7 - +9V
Pin 8 – Signal Gnd
Pin 9 – RP SW3/
Pin 10 – Connect/
Pin 11 – CLK Out
Pin 12 – Data Out
Pin 13 – Strobe Out
Pin 14 – RP SW1/
Pin 15 – Signal Gnd
Pin 16 – VCC
Pin 17 – Battleshort/
Pin 18 – Enable1
Pin 19 – Enable2
Pin 20 – Enable3
Pin 21 – Enable4
Pin 22 – Enable5
Pin 23 – Enable6
Pin 24 – Enable7
Pin 25 – Enable8

RS232 CONNECTOR

See page 18

SUMMARY OF INDICATORS AND CONTROLS

UPS FRONT PANEL

INPUT POWER SWITCH - This is system input AC power protection and interruption for both hot and neutral lines. This is a circuit breaker that if tripped, unit operation will continue on battery reserve. This circuit breaker is rated at 30A and is guarded to prevent inadvertent operation.

SYSTEM ON/OFF SWITCH - This is system input enable switch. This switch is used to power down the system. This switch must be in the ON position in order to AC or DC start the UPS.

AC INPUT LED - A green L.E.D. that is illuminated when the **INPUT POWER** Circuit Breaker is closed and there is AC input power available to the UPS.

LOAD LEDs - Four green L.E.D.s and one red OVERLOAD L.E.D. that illuminate to update status of the amount of load the INVERTER is powering at the UPS system output. Each green L.E.D. represents approximately 25% of full load. As more load is added to the UPS, the L.E.D.s will sequentially turn "ON" until the red L.E.D. comes "ON". This indicates an OVERLOAD situation and the system will discontinue operation shortly.

BATTERY LEDs - Four green L.E.D.s and one green LOW BATTERY L.E.D. that illuminate to update status of the battery energy available during a power outage. Each green L.E.D. represents approximately 20% of battery reserve power available. As battery discharge continues, the L.E.D.s will sequentially turn "OFF" until the last L.E.D. starts to flash. This indicates a LOW BATTERY situation and the system will discontinue operation shortly. Once utility power is returned to the system, this bar graph will show an approximate battery state as it reaches full charge. The top L.E.D. indicates charger on/off when unit running on AC. L.E.D. ON Charger OFF, L.E.D. OFF Charger ON.

AC IN OK LED- A green L.E.D. that is illuminated when the AC input is within operating limits. Upon startup of the UPS, good utility power is approx. 100Vac-130Vac. Once UPS is running, range would be approx. 85Vac-155Vac.

ON BATTERY LED - A red L.E.D. that is illuminated when the AC input is interrupted to the power electronics either externally or internally from the microprocessor due to an out-of-range situation. The output load is then supported entirely by battery energy through INVERTER operation.

AC OUTPUT LED - A green L.E.D. that illuminates when the INVERTER generator is operating and available to deliver power to the system output.

COLD START SWITCH - This is a momentary, push button switch. If no AC utility voltage is available, it may still be a requirement to initialize some equipment. When this switch is pressed in for at least two seconds, the system will start up on battery power. The SYSTEM ON/OFF Switch on the Front Panel of the unit and the POWER Switch on the Control Panel must be in the ON position for this function to operate. The green L.E.D. above this switch will light only while the switch is held in.

COLD START LED - A green L.E.D. that illuminates when the cold start switch is pressed.

LOAD ON/OFF SWITCH - Push button switch that enables output circuits when turned ON, disables output circuits when turned OFF.

BYPASS LED - A red L.E.D. above the LOAD ON/OFF SWITCH will light to indicate when the system output is operating in the filtered, emergency BYPASS mode. This is an unprotected power source that will not support the load in the event of a power failure.

BATTERY TEST SWITCH - This is a momentary, push button switch. Battery condition is vital to the UPS performance, particularly during a power outage. During normal operation with inverter ON, load applied to the unit and the Battery Bar Graph showing the battery at a full charge, this function switch may be used. By pressing this switch in for at least two seconds, a battery acceptance diagnostic will be run by the internal microprocessor. During the battery test, the Replace L.E.D. will flash and the On Batt L.E.D. will be lit. The test will run for approx. 30 seconds.

REPLACE BATTERY LED – After the battery acceptance diagnostic test has discovered that the batteries are excessively fatigued, the amber L.E.D. above this switch will light advising the user that the Batteries are bad and should be replaced or battery module is not connected to the UPS.

ALARM RESET SWITCH - This is a momentary, push button switch. During a system *FAULT* or power failure, an audible alarm will be present. Once this switch is pressed in for at least two seconds, the audible alarm will be silenced. The L.E.D. above the switch will remain unchanged. Additional Alarm conditions will re-annunciate the alarm, which then can be silenced again.

FAULT LED - If a FAULT condition occurs, this red L.E.D. will illuminate.

UPS REAR PANEL

INTERFACE - One CPC Type, 37 position reversed sex connectors provided for critical loads. Continuous power is provided here and is monitored by the LOAD L.E.D.s as long as the INVERTER is functioning. The Loads ON/OFF Switch must be enabled for power to be present here. 120VAC Fan Power, Fan sensor and Temp sensors are also provided.

RS232 CONNECTOR - DB-9 subminiature female connectors provided for intelligent computer monitoring systems. See SIGNALS AND INTERFACING Section for specific pin-outs.

CONTROL PANEL CONNECTOR - DB-25 subminiature female connectors provided for interfacing the control panel. See SIGNALS AND INTERFACING Section for specific pin-outs.

INPUT – One CPC Type, 3 position inlet connector for AC input.

GROUND - A 10-32 x 3/4 threaded stud for system rack grounding.

SNMP INTERFACE - (OPTIONAL) An add-on card that provides Simple Network Management Protocol (SNMP) access to the UPS controller via a RJ45 connector (LAN). The second RJ45 connector (RS232) provides a second RS232 port to the controller.

CONTROL PANEL

The following illustrations depict the basic Control Panel used with the **CMN Series** unit. Reference the **SUMMARY OF INDICATORS AND CONTROLS** Section for a further description of the call-outs.

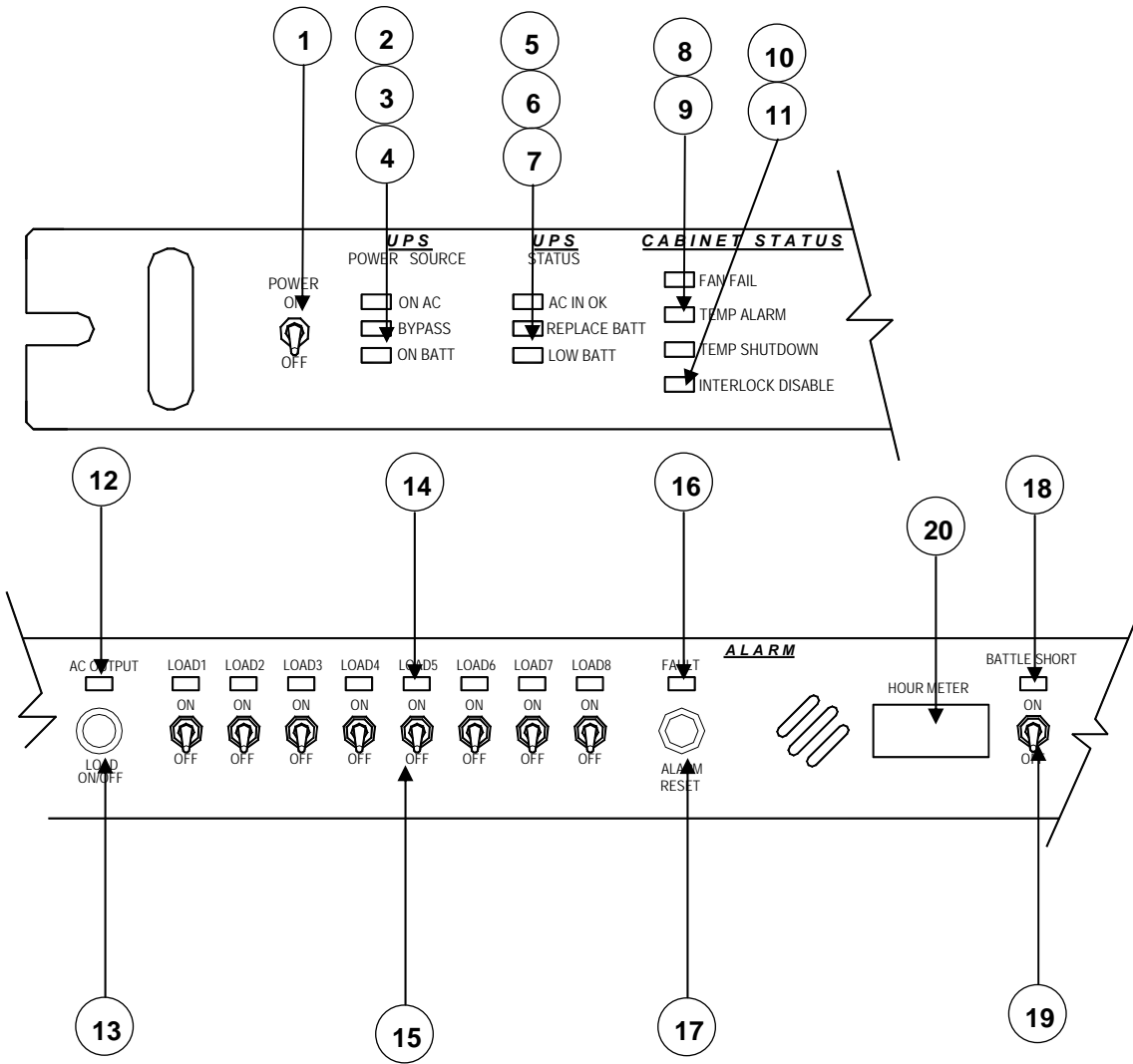
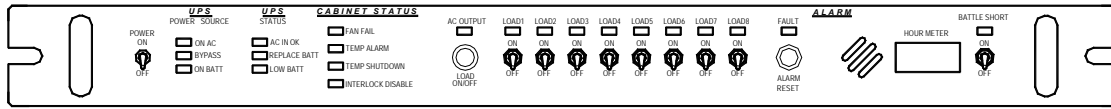

FIGURE 5: PANEL FRONT VIEW

SUMMARY OF INDICATORS AND CONTROLS

CONTROL PANEL

- 1 POWER SYSTEM ON/OFF SWITCH** When ON, enables UPS after UPS Input Power and System switches have been turned ON.
- 2 ON AC LED** Green illumination indicates that the UPS is running in normal operation on utility.
- 3 BYPASS LED** Red illumination indicates that the UPS is in Bypass. Bypass can result from certain board failures. Note: Battery backup is not available.
- 4 ON BATT LED** Red illumination indicates that the UPS is running on Battery.
- 5 AC IN OK LED** Green illumination indicates that the AC input is within operating limits.
- 6 REPLACE BATT LED** Red illumination indicates that the batteries are fatigued and need to be replaced.
- 7 LOW BATT LED** Red illumination indicates battery charge level is low.
- 8 FAN FAIL LED** Red illumination indicates cabinet fan status when logic level fan sensors are present.
- 9 TEMP ALARM LED** Yellow illumination indicates that the rack temperature is above the warning sensor limit when sensor is present.
- 10 TEMP SHUTDOWN LED** Red illumination indicates the rack temperature is at the shutdown level. After 40 seconds, loads 1-8 will shut off unless the Battle Short switch is ON. Once temperature shutdown is deactivated, loads 1-8 will turn ON one at a time.
- 11 INTERLOCK DISABLE LED** Yellow illumination indicates interlocks are disabled. This model does not have Interlocks.
- 12 AC OUTPUT LED** Green illumination indicates output power is available.
- 13 LOAD ON-OFF** Push button switch that enables output circuits when turned ON, disables output circuits when turned OFF.
- 14 LOAD INDICATORS 1 THROUGH 8** Green illumination indicates Loads 1-8 are active. Corresponding switch needs to be switched ON to enable.
- 15 LOAD ON/OFF SWITCHES 1 THROUGH 8** Locking switches that turn On and Off corresponding outputs. Pull then switch to enable/disable.
- 16 FAULT LED** Red illumination indicates internal fault identified by UPS electronics.
- 17 ALARM RESET SWITCH** Push button switch that silences Audible Alarms.
- 18 BATTLE SHORT LED** Red illumination indicates the UPS has been set to ignore over temperature conditions.
- 19 BATTLE SHORT SWITCH** Locking switch, when ON, it disables UPS Over temperature control inputs.
- 20 HOUR METER** Elapsed time meter. Indicated the total time the UPS/Control panel has been powered On.

SPECIFICATIONS

ELECTRICAL

Input	
Voltage	120VAC +35%, -20% (without Battery discharge)
Frequency	60Hz or 50Hz
Current	25A max @ 120Vac
Output	
Voltage	120VAC \pm 3%
Frequency	60Hz or 50Hz \pm .25% (software selectable)
Current	20A (2400VA)
Crest Factor Ratio (Non-linear load and less than 5% THD) Typical	@50% Load Up to 4.8:1 @75% Load Up to 3.2:1 @100% Load Up to 2.4:1
Harmonic Distortion	5% Max. THD
Dynamic Response	\pm 4% for 100% Step Load Change, 0.5 Millisecond Recovery Time
Overload	110% for 10 Minutes; 200% for 50 milliseconds
Efficiency (UPS)	85%
Load Power Factor	0.7
UPS Protection	Input and Output Short Circuit; Input and Output Overload; Excessive Battery Discharge

MECHANICAL

Input	CPC Type 3 position Inlet connectors
Output	CPC Type 37 position reversed sex Connector
Overall Dimensions L x H x W	23 in x 5.25 in x 19 in. (58.4 cm x 13.3 cm x 48.3 cm)
Weight	120 lb. (54.4 kg)
Cooling	Low Velocity, Forced Air

CONTROLS AND INDICATORS

Visual Indicators	Battery Level, Load Level, Battle short AC Input AC Output Battery On Bypass On Cold Start Fault Replace Battery
Audible Alarms	Utility Interrupt, Inverter Failure, Overload, Low Battery, fan fail, warm and overtemp.
Intelligent Computer Interface (DB-25F)	Full Interactive, Remote Computer Monitoring and Control of UPS Functions (RS232 Interface); Open-collector Alarm Signals interface to control panel

DESIGN

Standard Features	Regenerative™ On-Line, Sinewave Inverter Powers Load Continuously Extended Brownout Protection, External Battery Connector, High Frequency, Digitally Controlled IGBT PWM, Power Factor Corrected on Input, Designed for Non-linear Loads, Continuous Operation on +35% Line, 2400VA: ?Min. Backup @ 1680 watts / ? Min. @840 watts
-------------------	--

ENVIRONMENTAL

Operating Temperature	32°F to 122°F (0°C to 60°C)
Humidity	0% to 95% non-condensing
Altitude	Sea Level to 10,000 Feet

INSTALLATION

This Rackmount system is designed for installation in a protected environment. This system may be installed in a 19" rack system. Some important points to consider when positioning a unit for operation:

- A 30A (preferably dedicated) outlet is accessible for the power connection to the unit. It is not recommended to modify the power cord in any way nor should an extension cord of any kind be used. **Never use a surge protected device on the output of this system.**
- The cord paths in the system installation should remain clear of foot traffic or anything else that may disturb permanent connection.
- The installation site should maintain an ambient air temperature of less than 140°F (60°C). When the environment for the system remains cooler during operation, there is less stress on the batteries and the internal electronics.
- The air inlets, vents and fan should not be obstructed or blocked in any way. The more breathing space the system has, the cooler it operates.
- The air should remain free from excessive dust and chemical fumes.
- The front panel is designed to fit in a standard 19" rack. This panel fills a 5.25 inch (3U) slot. Guide Rails or slides are recommended to support the unit's mainframe. This system weighs in excess of 100 pounds. The front panel mounting screws are not intended to support the entire unit. The system comes with pre-tapped slide mounting holes.

Once a location has been selected and the unit is installed, it is ready for operation.

FIGURE 6:

OPERATION

- ⇒ Plug in the Control Panel (UPS Connector) with a male to female DB25 cable to the DB25 “Control Panel” Connector on the back of the unit.
- ⇒ Be sure the power cord is plugged into an appropriately rated outlet.
- ⇒ Activate the **INPUT ON/OFF** Circuit Breaker to the “ON” position on the UPS.
- ⇒ The AC INPUT L.E.D. will illuminate.
- ⇒ Activate the UPS Front Panel **SYSTEM ON/OFF** Switch to the “ON” position. Activate the Control Panel **POWER ON** switch to the “ON” position. Both switches must be “ON” to turn on the unit.
- ⇒ The system will go through a diagnostic test routine.
- ⇒ The green **AC IN OK** L.E.D. will flash several times before it illuminates solid.
- ⇒ Green **BATTERY** L.E.D.s will illuminate.
- ⇒ The audible alarm will sound a short burst.
- ⇒ Push and hold in the **LOAD ON/OFF** Switch for at least two seconds. You can use either Load ON/OFF Switch from the UPS or the Control Panel.
- ⇒ On the UPS, the **AC OUTPUT** L.E.D. will illuminate. On the Control Panel, you will see the **AC OUTPUT** L.E.D. illuminate and the loads 1-8 will illuminate in a sequence (if Load switches are in the “ON” position).

Switch the **INPUT ON/OFF** Circuit Breaker “OFF”. This will simulate a power loss to test battery operation.

- ⇒ The green **AC IN OK** L.E.D. will flash every two to three seconds. On the Control Panel, the **ON BATT** L.E.D. will illuminate and the **ON AC** L.E.D. will turn off.
- ⇒ The red **ON BATT** L.E.D. illuminates on the UPS.
- ⇒ An intermittent audible alarm will sound. (The **ALARM RESET** Switch may be operated at this time, it must be held in for at least 2 seconds to silence the alarm.)
- ⇒ As battery discharge continues in this condition, the five green **BATTERY** L.E.D.s will start to shut off. Each led represents approximately 20% of the battery reserve available. If this were to continue until all four L.E.D.s shut off, the last green L.E.D. will flash, indicating that a **LOW BATTERY** situation is present and system shutdown is imminent. The **LOW BATT** L.E.D. on the Control Panel and the UPS will illuminate. The intermittent audible alarm will become continuous at this point. The UPS will automatically shut itself off to avoid excessive battery discharge. When power returns, normal operation of the UPS resumes without any operator interaction.

1. The duration of actual battery backup time and the **LOW BATTERY** condition varies depending on the amount of load, charge on the battery, and condition of the battery.

To check the battery;

- ⇒ Push and hold the **TEST** switch in for at least two seconds.

⇒ The amber **REPLACE BATT** L.E.D. will flash and the audible alarm will sound.

The microprocessor will run a battery diagnostic check.

⇒ The Control Panel audible alarm will sound after the test.

If the battery is found to be fatigued compared to predetermined or typical battery parameters, the amber **REPLACE BATT** L.E.D. will illuminate, suggesting the user replace the batteries. If the SNMP battery test function is enabled, the microprocessor automatically runs this test. The user will be alerted of a faulty battery or battery not connected to the UPS.

Activate the **SYSTEM ON/OFF** Switch to the “OFF” position to discontinue system operation.

Turn off the devices you wish to plug into the UPS. Connect them to the output at the rear of the unit. Do not exceed the output ratings of the system.

⇒ Activate the **SYSTEM ON/OFF** Switch to the “ON” position.

⇒ The system will go through a diagnostic test routine and test all the L.E.D.s with the exception of the **COLD START** L.E.D.

⇒ Push and hold in the **LOAD ON/OFF** Switch for at least two seconds.

⇒ The **AC OUTPUT** L.E.D. will illuminate indicating output power is available at the rear panel outlets.

⇒ Turn “ON” the Load Switches on the Control Panel.

⇒ Turn “ON” each of your devices.

⇒ Some of the four green L.E.D. **LOAD** indicators should illuminate. The amount of load is determined by the actual number of indicators lit.

Each L.E.D. signifies approximately 25% of load capacity. If all four L.E.D.s illuminate, full load has been achieved. If the red light illuminates, an **OVERLOAD** condition is present. If this situation continues beyond three seconds, the unit will automatically shut off, discontinuing all operation including the output to the load. The red **FAULT** L.E.D. will light and a continuous alarm will be heard. The load must be reduced and the **SYSTEM ON/OFF** Switch will have to be reset in order to return to normal operation.

If the system overheats or the **INVERTER** should fail, the unit automatically transfers power to the **BYPASS** line to maintain uninterrupted power to the load. The red **BYPASS** L.E.D., above the **LOAD ON/OFF** Switch, will light. A continuous alarm will sound and the red **FAULT** L.E.D. will illuminate.

To escape this condition, the problem must first be corrected, then the **SYSTEM ON/OFF** Switch must be reset.

To DC Start the unit:

⇒ Activate the UPS Front Panel **SYSTEM ON/OFF** Switch to the “ON” position. Activate the Control Panel **POWER ON** switch to the “ON” position.

⇒ Push and hold the **COLD START** switch on the UPS until the alarm sounds once.

⇒ Push and hold in the **LOADS ON/OFF** Switch for at least two seconds. You can use either Loads ON/OFF switch from the UPS or the Control Panel.

⇒ The **AC OUTPUT L.E.D.** will illuminate indicating output power is available at the rear panel outlets.

The **ALARM RESET** Switch on the front panel of the UPS or the Control Panel can be used at any time to silence the audible alarm. This switch must be held in for at least two seconds before the alarm will quiet. The **FAULT L.E.D.** above this switch will remain unchanged while operating this switch.

ALLOW AT LEAST 24 HOURS, AFTER THE SYSTEM IS FIRST INSTALLED, TO FULLY CHARGE THE BATTERIES TO A MAXIMUM STATE.

SIGNALS AND INTERFACING

This system is designed to be compatible with most sophisticated operating systems when they feature a UPS monitoring function. These signals are made available through the DB-25 subminiature female connector at the rear of the Control Panel. Interfacing cables are available. The communications connector at the rear of the UPS is for a RS232 interface connection. The Remote Panel connector features open-collector alarm signals. Closing the points between pins 6 and 8 while running on battery will shutdown the UPS. Below is a diagram of the signal jacks and their pin-outs:

RS232 CONNECTOR

- 1- LOW BATT
- 2- TX
- 3- RX
- 4- DTR
- 5- SIGNAL GROUND
- 6- DSR/+9V
- 7- RTS IN
- 8- AC INPUT FAIL

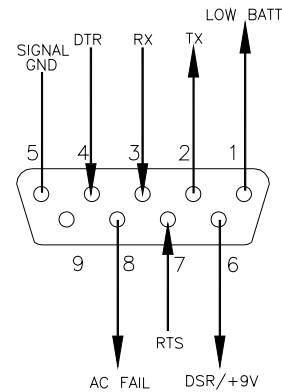

NOTE: Pin 4 enables a relay on the Interface board that allows communications directly with the UPS from the RS232 Connector. When relay is enabled, SNMP is disabled.

REMOTE PANEL CONNECTOR ON THE REAR OF THE CONTROL PANEL

- 2 & 14- AC INPUT FAIL
- 3- UPS ON
- 4 & 15- GROUND
- 5 & 9- LOW BATTERY
- 6- REMOTE SHUTDOWN+
- 7- +9VDC
- 8- REMOTE SHUTDOWN (RETURN)

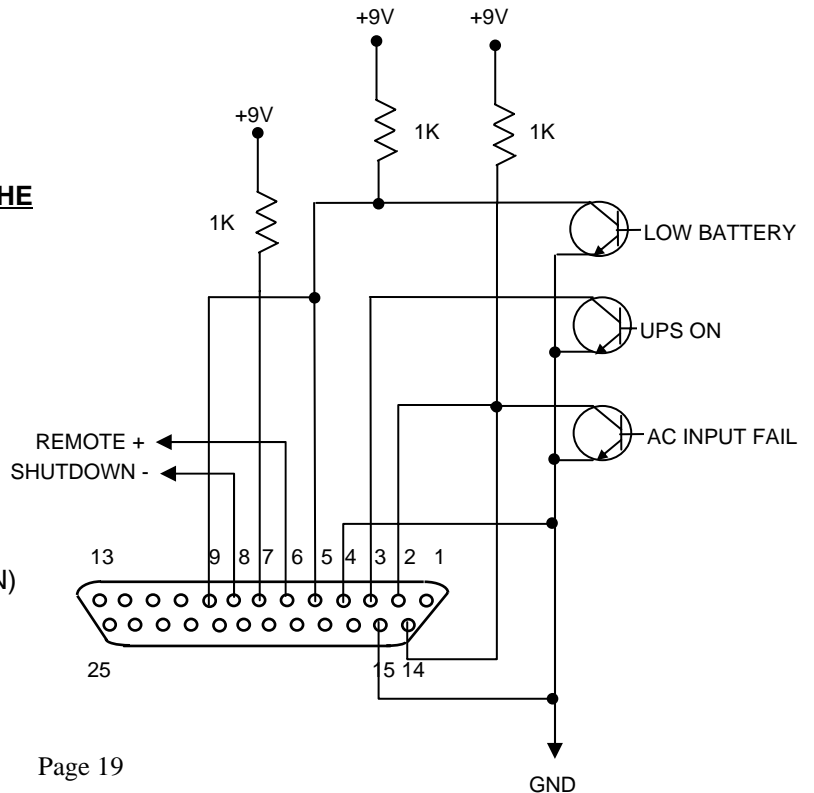

CARE & MAINTENANCE

This system is designed to be maintenance-free. It can be cleaned with a damp cloth or non-abrasive cleanser.

Be sure filters and vents are kept free from accumulation of dust, dirt or lint.

If the unit is placed in storage, it is recommended that the battery be fully charged. Never allow the battery to remain in a discharged state for an extended period of time. Also, when storing units, the batteries should be recharged every 90 days. To recharge the batteries in a stored unit, it must be plugged in and the inverter needs to be switched "ON". Allow the system to charge for at least 24 hours.

WARNING: Never attempt to service the batteries. High voltage exists within the unit, which could cause electrical shock. Servicing of batteries should be performed or supervised by personnel knowledgeable of batteries and the required precautions. Keep unauthorized personnel away from the batteries.

WARNING: Only replace batteries with Clary part number 223-15176.

CAUTION- Do not replace the individual batteries in the battery pack.

CAUTION- Do not dispose of battery or batteries in a fire. The battery may explode.

CAUTION- Do not open or mutilate the battery or batteries. Released electrolyte is harmful to the skin and eyes. It may be toxic.

CAUTION- A battery can present a risk of electrical shock and high short circuit current. The following precautions should be observed when working on batteries.

1. Remove watches, rings, or other metal objects.
2. Use tools with insulated handles.
3. Wear rubber gloves and boots.
4. Do not lay tools or metal parts on top of batteries.
5. Determine if the battery is inadvertently grounded. If inadvertently grounded, remove source of ground. Contact with any part of a grounded battery can result in electrical shock. The likelihood of such shock will be reduced if such grounds are removed during installation and maintenance.

BATTERY PACK INSTALLATION AND REPLACEMENT

REPLACING THE BATTERY PACK

Your new replacement Battery Pack (223-15176) was designed as a plug in, hot swap battery pack that can be ordered separately.

CAUTION: Before removing the battery pack from your system, insure that you have a replacement battery pack readily available.

Remove new battery pack from shipping box prior to uninstalling existing battery pack. This packaging will aid in return or disposal of your old used batteries. Prior to removal of existing battery pack insure that your UPS System is secured into a fixed position in a rack or it is sitting flat on a work bench or other flat firm surface. Locate the six flat head machine screws holding the battery pack into position. Remove existing battery pack using the steps below. Upon sliding the battery pack out, it will hang up at the rear before it comes out of the UPS. This will help you feel the weight of the battery pack prior to full removal. Lift the battery pack a little and it can be safely removed. To install new battery pack, repeat the steps below in reverse order.

CAUTION: The battery pack is heavy (48 pounds), handle with care not to damage rear connectors.

1. Remove the six 10-32X1/2 screws from the front of the battery pack.
2. With one hand grab the front handle and slowly pull out about 8 inches.
3. Place other hand under battery pack for support and slowly pull all the way out.

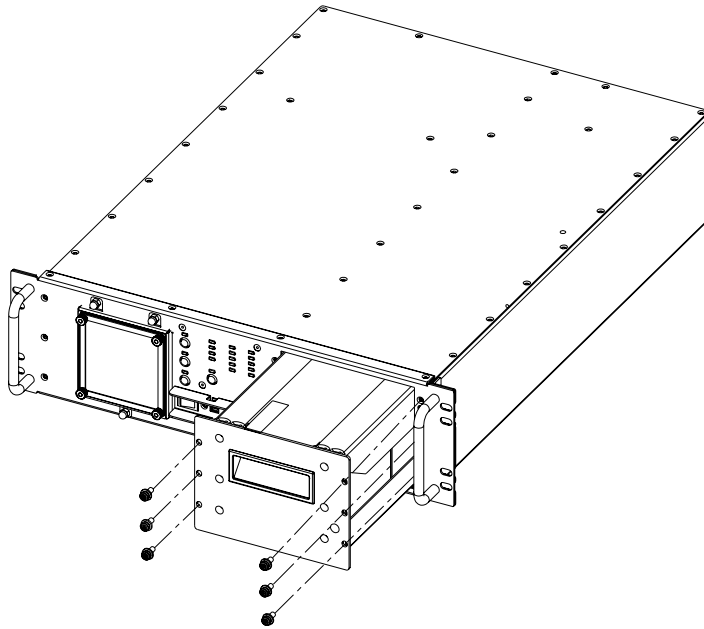

SERVICE AND REPAIR

This **CMN Series** Rackmount is backed by one of the finest customer service teams assembled. Write or call them at any time to obtain information about your unit.

Clary Corporation
150 E. Huntington Dr.
Monrovia, CA 91016

626-359-4486
800-551-6111
SERVICE@CLARY.COM

If a problem should occur, it is important that you obtain a Return Material Authorization (RMA) number from the Service Department to process any unit returned to the factory. In consulting the factory, **always have the unit model number and serial number at hand**. This information is located on the identification label on the left side and is essential in retrieving your unit's performance and history record.

The RMA number issued to you should appear on the outside of the carton, if the unit is returned, or on any correspondence regarding your unit. When shipping a unit back to the factory, try to use the original packing container and shipping materials. Shipping materials are available through the Service Department if the original container is unobtainable. The Service Department cannot take responsibility for any unit damaged in return shipment. All units must be returned prepaid to:

CLARY SERVICE DEPT.
150 E. Huntington Dr.
Monrovia, CA 91016

FCC CONSIDERATIONS

This equipment generates and uses radio frequency energy and if not installed and used properly in strict accordance with the manufacturer's instructions, may cause interference to radio and television reception. The unit in this manual has been tested and found to comply with the limits for a Class A computing device in accordance with the specifications in Subpart J of Part 15 of FCC Rules, which are designed to provide reasonable protection against such interference in a commercial installation. However, there is no guarantee that interference will not occur in a particular installation. If this equipment does cause interference to radio and television reception, which can be determined by turning the equipment off and on, the user is encouraged to try to correct the interference by one or more of the following measures:

- Reorient the receiving antenna.
- Relocate the UPS with respect to the receiver.
- Move the UPS away from the receiver.
- Plug the UPS into a different outlet so that the UPS and receiver are on different branch circuits.

If necessary, the user should consult the dealer or an experienced radio/television technician for additional suggestions. The user may find the following booklet prepared by the Federal Communications Commission helpful:

"How To Identify and Resolve Radio-TV Interference Problems"

This booklet is available from the U.S. Government Printing Office,
Washington, DC 20402, Stock No. 004000003454.

WARRANTY

1. TIME AND SCOPE OF WARRANTY:

- 1.1 Clary Corporation hereby warrants all equipment shipped under this Agreement to be free from defective components and workmanship for a period of 2 years (3 years with purchase of an one year extended warranty) following date of shipment. Accidental damage, misuse or normal wear shall not be construed as a defect.
- 1.2 The date of shipment as used herein will be the date on Clary's Bill of Lading. If no Bill of Lading is issued, the date of shipment shall be shown on seller's shipping document.
- 1.3 No provision of this warranty shall cover equipment, which has been altered or modified from the original specifications to which it was manufactured, unless authorized in writing.
- 1.4 No provision of this warranty shall cover batteries. However, battery manufacturer's warranties will be passed through to the customer whenever applicable.

2. LIMITS OF "IN-WARRANTY" SERVICE LIABILITY

- 2.1 Clary is obligated during the in-warranty period to provide service and/or adjustments to equipment returned to the factory at the expense of the buyer. (The term "factory" as used herein shall also include any field service centers, which may be established by Clary.) Clary is to repair or replace any part(s) thereof, which in the opinion of authorized Clary personnel are found to have been defective.
- 2.2 Equipment requiring in-warranty service must be returned to the factory with all transportation charges prepaid. Equipment must be clearly tagged stating the nature of the trouble experienced and the disposition of the equipment after repair. The equipment will be returned freight collect by Clary to the location specified via the best, least expensive carrier available, or via customer's shipping instructions.
- 2.3 The nature of certain equipment installations may be such that it would be impractical or technically infeasible to remove the Clary portion of the equipment from the customer's premises to the Clary factory. In such cases, and at the request of the buyer, Clary will perform such service as can be satisfactorily rendered at buyers location. The buyer will be charged only for travel expenses incidental to the service call, provided that the warranty is applicable.
- 2.4 During the in-warranty period, no service charges shall be payable by the buyer for service performed other than for service necessitated by accident, misuse, theft, abnormal line or source voltage fluctuations, abnormal conditions of operation, damage by the elements or damage resulting from adjustments, repairs, modifications made by other than Clary Authorized personnel, or the buyer's failure to reasonably maintain the equipment

THE FOREGOING WARRANTY IS EXCLUSIVE AND IS GIVEN AND ACCEPTED IN LIEU OF ANY AND ALL OTHER WARRANTIES, EXPRESSED OR IMPLIED. INCLUDING WITHOUT LIMITATION THE IMPLIED WARRANTIES OF MERCHANTABILITY AND FITNESS FOR A PARTICULAR PURPOSE. THE REMEDIES OF BUYER SHALL BE LIMITED TO THOSE PROVIDED HEREIN. IN NO EVENT WILL SELLER BE LIABLE FOR COLLATERAL OR CONSEQUENTIAL DAMAGES. No person is authorized to assume in behalf of Clary any obligation or liability in connection with the sale, warranty or service policy of any products manufactured and/or marketed by Clary Corporation beyond the warranty description on the face hereof.

- 3.1 Clary Corporation reserves the right to make changes, additions, and/or improvements in its products without incurring any obligation to install them on its products previously sold.