



smaller footprint!
space saving design!
1.7"H x 11"W x 8.5"D

SP560

Uninterruptible Power for Traffic, IT & Security Applications

Industry proven, on-line protection, 100% of the time, for reliable and continuous error-free operation, regardless of utility power quality.

The CLARY SP560 is a 400W/560VA 120VAC power source for electronics equipment in IT, Traffic, and Security applications. The SP560 delivers constant, conditioned, regenerated AC power which protects equipment from being disrupted, degraded or damaged due to harmful power events. CLARY power conditioning completely isolates the cabinet from utility power enabling error-free operation during surges, sags, spikes, and other power anomalies. With an optional battery pack, the SP560 system operates as an On-Line, Double-Conversion UPS that extends the reliability of the cabinet's electronics during utility power failures (black-outs). The SP560 is Power Factor Corrected to reduce utility current draw and wiring requirements.

Designed for indoor/outdoor use, the CLARY SP560 will operate in temperature extremes from -40°C to +70°C (-40°F to 165°F). Occupying only 1U of Vertical Rack Space, its 8.5" x 11" footprint can fit any cabinet. The SP560 communicates locally or remotely via serial, USB or an optional web agent.

Quick Read Features:

- **Space Saving Design:**
1U Vertical Rack Space
- **On-Line, Conditioned, Regenerated Power**
for Cabinet Equipment Protection
- **USB Connectivity with Monitoring Center or Other Equipment**
- **Power Factor Corrected for Reliable & Safe Power**
- **Operates in Extreme Environments from -40°C to +74°C (-40°F to +165°F)**

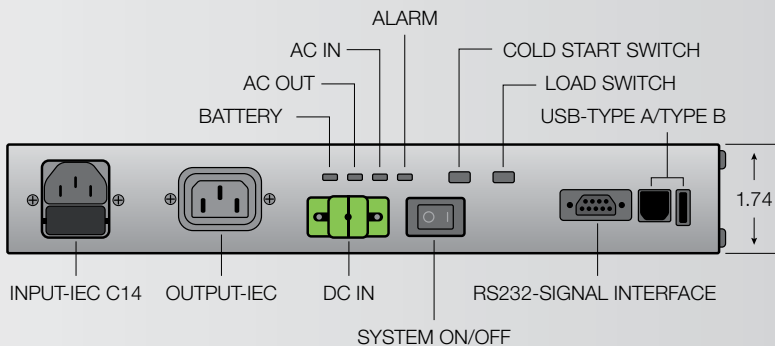

Front Panel shown is the actual width (11") of the SP560. Its depth (8.5") is the width of this datasheet. In most applications it is mounted horizontally.



SP560 Specifications

Electrical

Input

Voltage	120 VAC, (85VAC to 155VAC before going to battery, when configured with batteries)
Frequency	40 to 70 Hz

Output

Voltage	120 VAC \pm 3%
Frequency	50 or 60 Hz \pm .25% (Software Selectable)
Current	4.8A (400W / 570VA)
Crest Factor Ratio (Non-linear Load and < 5% THD)	@50% Load Up to 4.8:1 @75% Load Up to 3.2:1 Typical @100% Load Up to 2.4:1

Total Harmonic Distortion	(THD) 3.0%
Dynamic Response	\pm 4% for 100% Step Load Change, 0.5 ms Recovery Time
Overload	110% for 10 seconds; 200% for 50 milliseconds
UPS Protection	Input and Output Short Circuit, Input and Output Overload, Excessive Battery Discharge

Mechanical

Input	IEC-320, C14 male connector
Outputs	IEC-320, C13 female receptacle
Overall Dimensions	11"W x 8.5"D x 1.7"H

Environmental

Operating Temperature	-40°F to +165°F (-40°C to +74°C)
Humidity	0% to 95% non-condensing
Altitude	Sea Level to 10,000 Feet

Options

Battery Chassis	External Battery Chassis supports UPS capability. Provides 6 minutes of back-up time at 100% load. Consult Factory for other Battery and Battery Chassis Options.
Rack Mount	Hardware to provide 19" Rack mounting capability.
By-pass Switch	Supports manual and automatic switching of SP560.

Design

Standard Features	Power Factor Corrected Input; Fully Regenerative; True On-Line Continuous Power; Low Distortion Sinewave Output; Designed for Non-linear Loads; Extended Brownout Protection
Specifications	Meets FCC Class A, IEEE 587/ANSI C62.41, IEC 555 @ 120 VAC and NEMA Standards
MTBF	Inverter: > 100,000 hrs System Calculated from Component Specifications
Typical Recharge Time to 85% Capacity @ 100% Load	3 to 5 hrs (with extended battery option)

Controls and Indicators

Visual Indicators	Battery Status; AC Output; AC Input; Alarm
Switches	System Power; Cold start; Load
Audible Alarms	Utility Interrupt; Inverter Failure; Overload; Low Battery; Over Temperature
Intelligent Computer Interfaces	1 each DB9-F (RS232 and Signal Interface pins) and 1 each USB

